



GALİPOĞLU
HIDROMAS

Phone : +90 332 239 08 52 (pbx)
 Fax : +90 332 239 08 51
 Mail : hidromas@hidromas.com
 Address : Büyükkayacık Mah. Konya O.S.B. 3 Nolu Sk No:1/A 42250
 SELÇUKLU / KONYA
 TÜRKİYE

GHS 197 x 5 x 5550 C

Stock Code : 43197555503

Reference No : 01-001

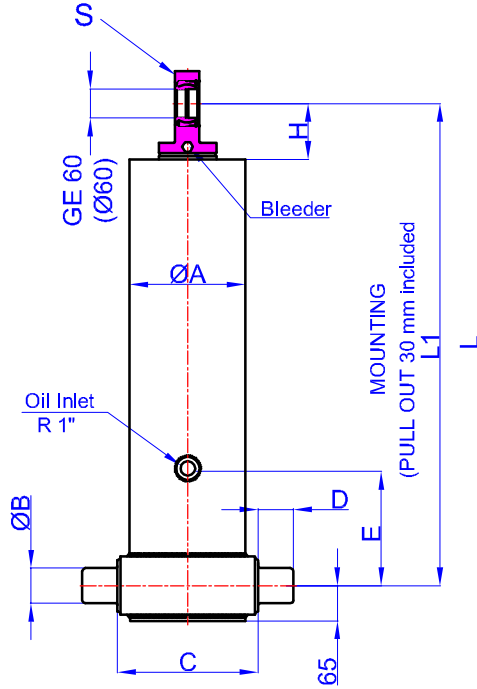

A	:	220	mm
B	:	65	mm
C	:	265	mm
D	:	60	mm
E	:	350	mm
H	:	95	mm
L	:	1395	mm
*L1	:	1425	mm
S	:	52	mm

* Inc 30 mm pull out :
 tolerance +20 -0
 Hard Chromed all stages
 Working Pressure : 170 Bar
 Max. Working Pressure : 190 Bar
 All Cylinder Materials are St
 52 Cold Drawn Tubes

STAGE	1	2	3	4	5	6	7	8	TOTAL
EFFECTIVE DIAMETER (mm)	Ø197	Ø175	Ø154,5	Ø135	Ø116				
STROKE	1110	1110	1110	1110	1110				5550
OIL DISPLACEMENT (L)	35,5	28	22	17	12,5				125
THRUST AT 170 BAR (TONS)	51	40	31	24	18				

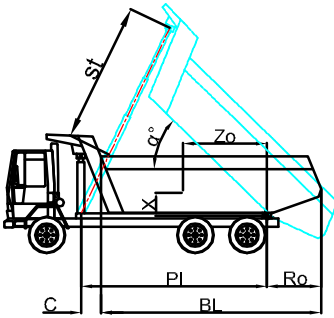

BL (body length)
 Ro (rear overhang)
 Ycog (vert. pos. centre of gravity)
 PI (Pivot length)
 $\alpha^\circ = \frac{st \times 60}{PI}$

	7100			6900			6700		
BL	200	500	800	200	500	800	200	500	800
Ro	45	47	50	46	49	51	48	50	53
Ycog	600	50	55	62	51	57	65	53	59
	900	55	61	70	57	63	74	59	67
	1200	60	68	81	62	72	87	65	76
st	5325	5326	5416	5290	5390	5355	5360	5333	5565

Weight : 285 Kg

Drawing No :43197555503-02-001