



GALİPOĞLU
HIDROMAS

Phone : +90 332 239 08 52 (pbx)
 Fax : +90 332 239 08 51
 Mail : hidromas@hidromas.com
 Address : Büyükkayacık Mah. Konya O.S.B. 3 Nolu Sk No:1/A 42250
 SELÇUKLU / KONYA
 TÜRKİYE

GHS 197 x 5 x 6425 C

Stock Code : 43197564253

Reference No : 01-001

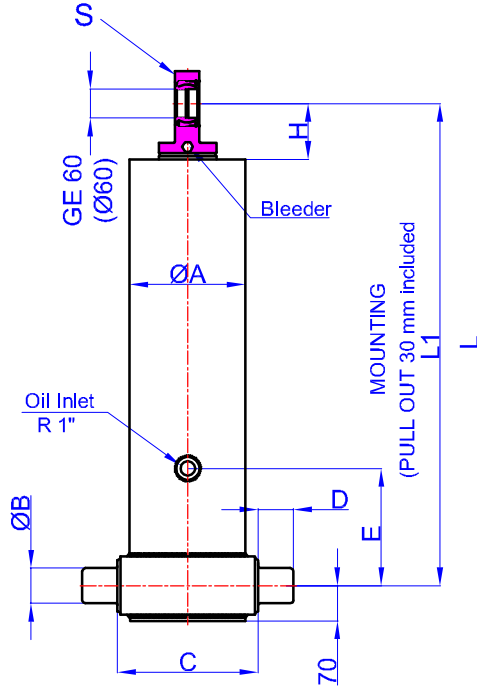

A	:	220	mm
B	:	65	mm
C	:	265	mm
D	:	60	mm
E	:	350	mm
H	:	95	mm
L	:	1590	mm
*L1	:	1620	mm
S	:	52	mm

* Inc 30 mm pull out :
 tolerance +20 -0
 Hard Chromed all stages
 Working Pressure : 150 Bar
 Max. Working Pressure : 180
 Bar
 All Cylinder Materials are St
 52 Cold Drawn Tubes

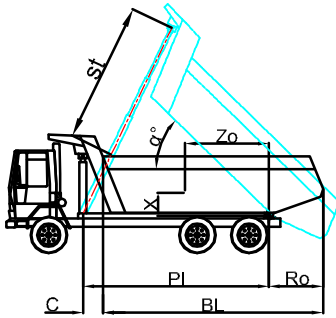

STAGE	1	2	3	4	5	6	7	8	TOTAL
EFFECTIVE DIAMETER (mm)	Ø197	Ø175	Ø154,5	Ø135	Ø116				
STROKE	1285	1285	1285	1285	1285				6425
OIL DISPLACEMENT (L)	41	32,5	25,5	19,5	14,5				145
135 BAR (TONS)	51	40	31	24	18				

BL (body length)
 Ro (rear overhang)
 Ycog (vert. pos.
 centre of gravity)
 PI (Pivot lengt)
 $\alpha^\circ = \frac{st \times 60}{PI}$

BL	8200	800	8000	800	7800	800	
Ro	200	500	200	500	200	500	
α°	45	47	46	48	47	49	
Ycog	600	54	59	55	60	57	
	900	53	64	60	67	62	
	1200	57	71	66	75	69	
	6150	6188	6206	6133	6160	6166	
					6110	6125	6240

Weight : 322 Kg

Drawing No :43197564253-18-001