

35 cc BI-ROTATIONAL GEAR PUMP-ISO
DPA 25-35 ÇİFT DÖNÜŞLÜ DİŞLİ POMPA

Product Code / Ürün Kodu : PDCD250350133
Ref. No : 0003

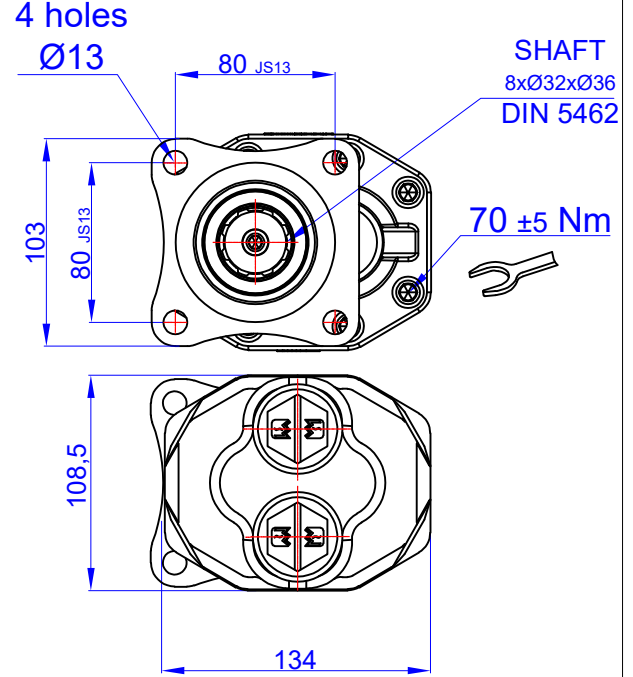
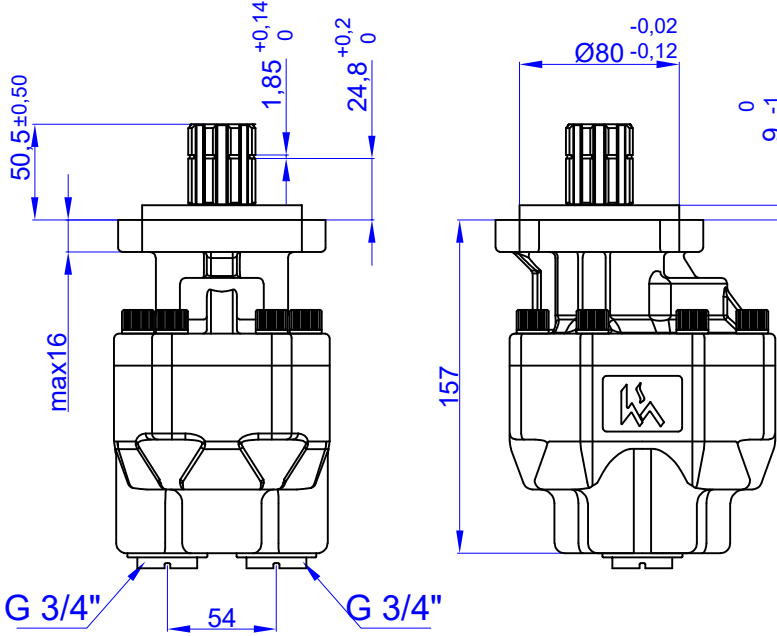

TEKNİK BİLGİLER / TECHNICAL DATA

Specifications		
Displacement	35	cm ³ /rev
Max. Peak Pressure (P3)	210	bar
Max. Intermittent Pressure (P2) (for tipping applications)	200	bar
Max. Continuous Pressure (P1)	180	bar
Max. Speed at Intermittent Press.	2300	min ⁻¹
Min. Speed at Intermittent Press.	300	min ⁻¹
Max. Speed at Continuous Press.	1700	min ⁻¹
Oil Temperature Range	-40 ~ 80	°C
Inlet Pressure Range (suction side)	0,7 ~ 3	bar
Recommended Oil Viscosity Range	12 ~ 100	mm ² /s (cSt)
Max. Starting Viscosity	750	mm ² /s (cSt)
Filtration :		
-Working Pressure < 200 bar	25	µm
-Working Pressure > 200 bar	10	µm
Connection :		
Min. Suction Hose Bore Diameter	-	inch
Weight	8,9	kg
Rust prevent oil applied shaft area	protect 12 moths	

Power and Torque					
Pressure (Bar)	50	100	150	200	210
Torque (Nm)	31	62	93	124	130

Power (kW)					
rpm / Bar	50	100	150	200	210
500	2	3	5	7	7
1000	3	7	10	13	14
1500	5	10	15	20	21
2000	7	13	20	27	28
2300	8	15	23	30	32

rpm (n/min)	Flow (L/min)
500	17
1000	34
1500	51
2000	69
2300	79

DİYAGRAMLAR / DIAGRAMS

Power-Pressure Graphic

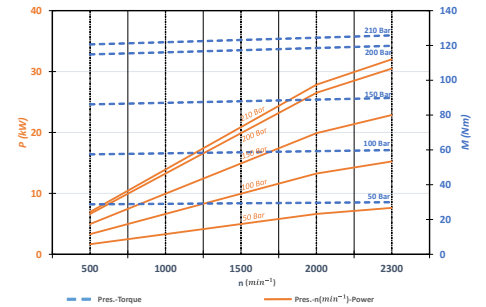

Flow-rpm Graphic

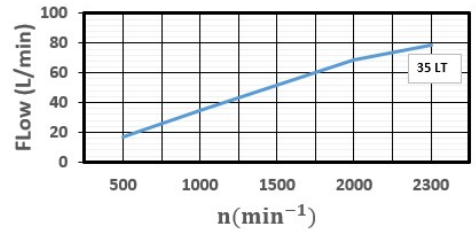

Torque-Pressure Graphic

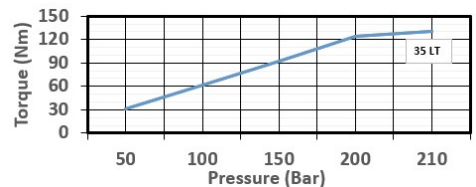

Pressure Definition

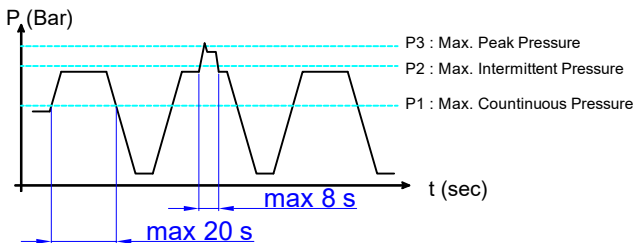

Hydraulic Pump Symbol

