

45 cc BI-ROTATIONAL GEAR PUMP-UNI  
DP 25-45 T1 ÇİFT DÖNÜŞLÜ DIŞLI POMPA

Product Code / Ürün Kodu : PDCD250450013  
Ref. No : 0001

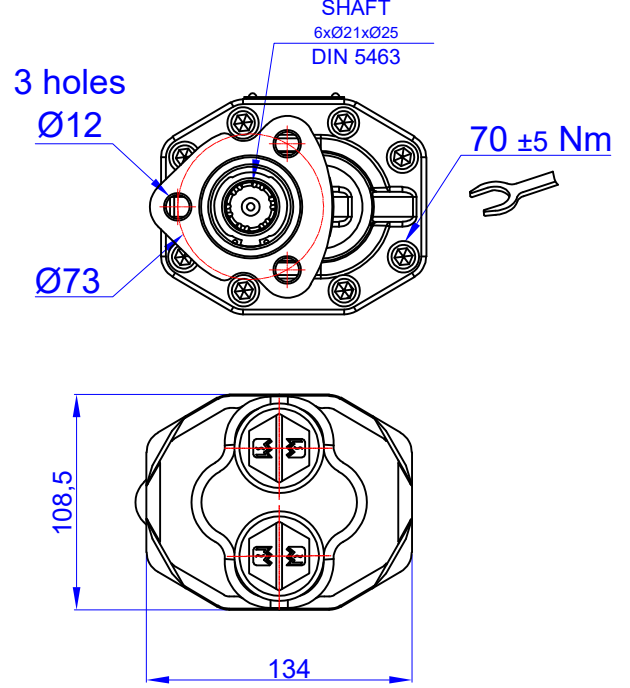
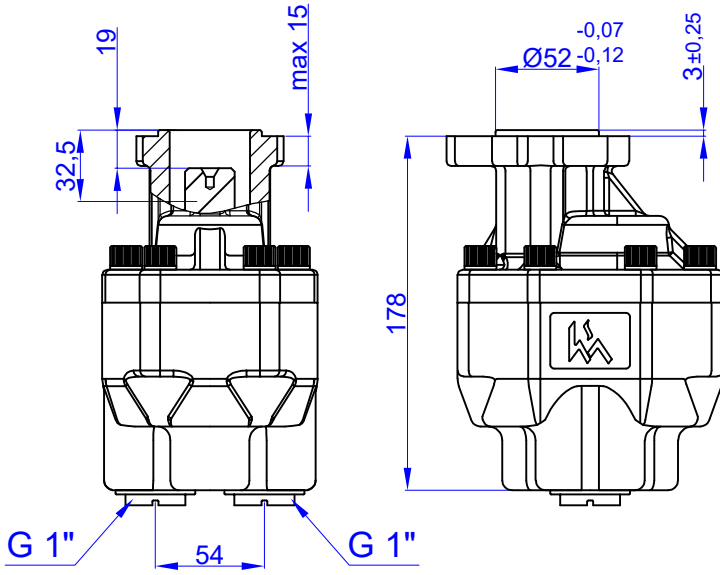

### TEKNİK BİLGİLER / TECHNICAL DATA

Specifications		
Displacement	45	cm <sup>3</sup> /rev
Max. Peak Pressure (P3)	200	bar
Max. Intermittent Pressure (P2) (for tipping applications)	190	bar
Max. Continuous Pressure (P1)	170	bar
Max. Speed at Intermittent Press.	2300	min <sup>-1</sup>
Min. Speed at Intermittent Press.	300	min <sup>-1</sup>
Max. Speed at Continuous Press.	1700	min <sup>-1</sup>
Oil Temperature Range	-40 ~ 80	°C
Inlet Pressure Range (suction side)	0,7 ~ 3	bar
Recommended Oil Viscosity Range	12 ~ 100	mm <sup>2</sup> /s (cSt)
Max. Starting Viscosity	750	mm <sup>2</sup> /s (cSt)
<b>Filtration :</b>		
-Working Pressure < 200 bar	25	µm
-Working Pressure > 200 bar	10	µm
<b>Connection :</b>		
Min. Suction Hose Bore Diameter	--	inch
Weight	8,8	kg
Rust prevent oil applied shaft area	protect 12 months	

Power and Torque					
Pressure (Bar)	50	100	150	170	200
Torque (Nm)	40	80	119	135	159

Power (kW)					
rpm / Bar	50	100	150	170	200
500	2	4	6	7	9
1000	4	9	13	14	17
1500	6	13	19	22	26
2000	9	17	26	29	34
2300	10	20	29	33	39

rpm (n/min)	Flow (L/min)
500	22
1000	44
1500	66
2000	88
2300	101

### Pressure Definition

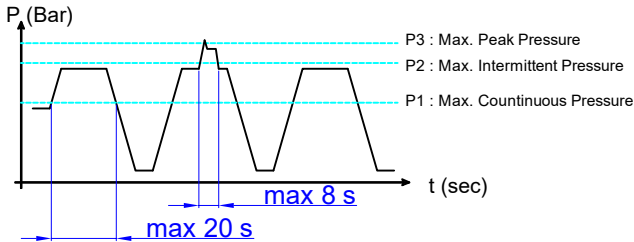

### Hydraulic Pump Symbol

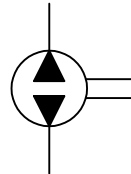

### DİYAGRAMLAR / DIAGRAMS

#### Power-Pressure Graphic

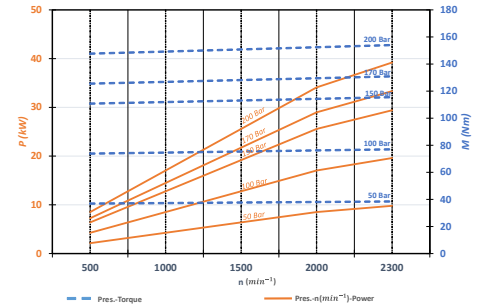

#### Flow-rpm Graphic

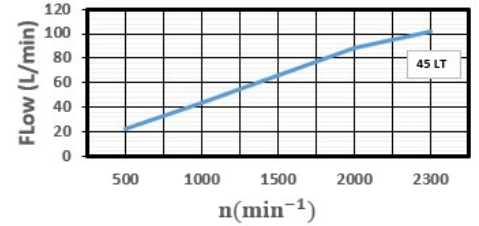

#### Torque-Pressure Graphic

