

27 cc GEAR PUMP-UNI
DP 30-27 DİŞLİ POMPA SAĞ / SOL

Product Code / Ürün Kodu : PDTD300270011
Ref. No : 0001 PDTD300270012

CW
CCW

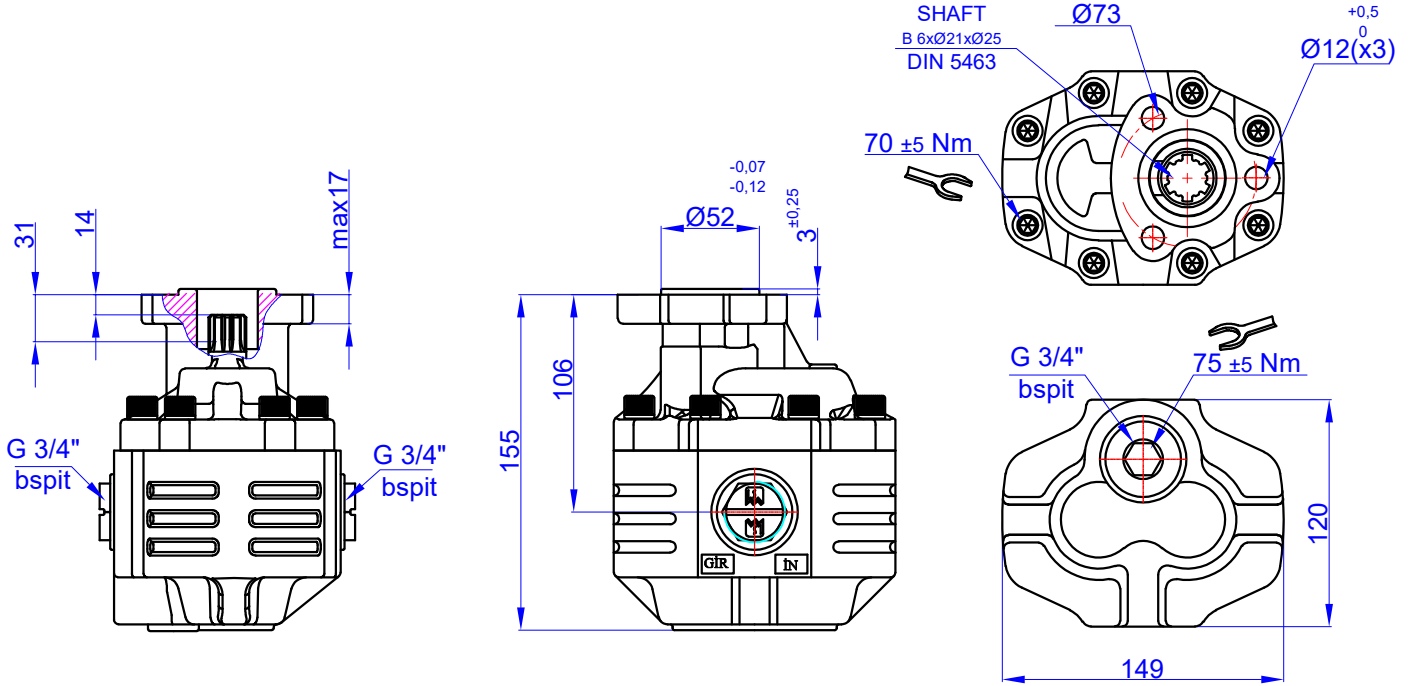

TEKNİK BİLGİLER / TECHNICAL DATA

Specifications

Displacement	27	cm ³ /rev
Max. Peak Pressure (P3)	325	bar
Max. Intermittent Pressure (P2) (for tipping applications)	315	bar
Max. Continuous Pressure (P1)	290	bar
Max. Speed at Intermittent Press.	3000	min ⁻¹
Min. Speed at Intermittent Press.	300	min ⁻¹
Max. Speed at Continuous Press.	2500	min ⁻¹
Oil Temperature Range	-40 ~ 80	°C
Inlet Pressure Range (suction side)	0,7 ~ 3	bar
Recommended Oil Viscosity Range	12 ~ 100	mm ² /s (cSt)
Max. Starting Viscosity	750	mm ² /s (cSt)
Filtration :		
-Working Pressure < 200 bar	25	µm
-Working Pressure > 200 bar	10	µm
Connection :		
Min. Suction Hose Bore Diameter	—	inch
Weight	9	kg
Rust prevent oil applied shaft area	protect 12 moths	

Power and Torque

Pressure (Bar)	50	100	200	300	325
Torque (Nm)	24	48	95	143	155

Power (kW)

rpm / Bar	50	100	200	300	325
500	1	3	5	8	8
1000	3	5	10	15	17
1500	4	8	15	23	25
2500	6	13	26	38	42
3000	8	15	31	46	50

rpm (n/min)	Flow (L/min)
500	13
1000	26
1500	40
2500	66
3000	79

DİYAGRAMLAR / DIAGRAMS

Power-Pressure Graphic

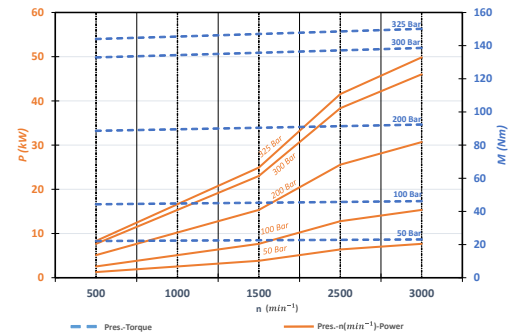

Flow-rpm Graphic

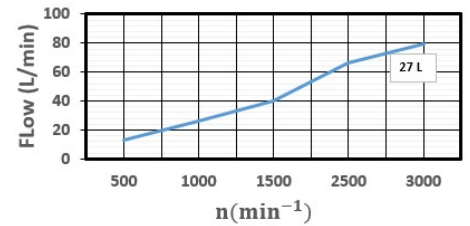

Torque-Pressure Graphic

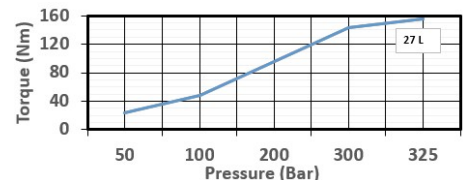

Pressure Definition

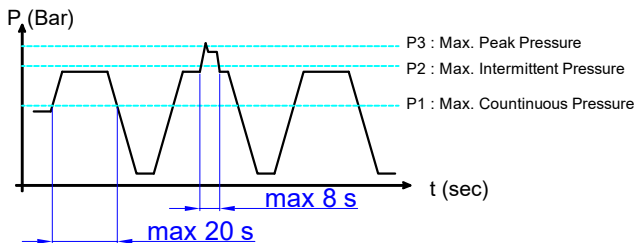

Hydraulic Pump Symbol

