

61 cc GEAR PUMP-UNI
DP 30-61 DIŞLI POMPA SAĞ / SOL

Product Code / Ürün Kodu : PDTD300610011
Ref. No : 0001 PDTD300610012

CW
CCW

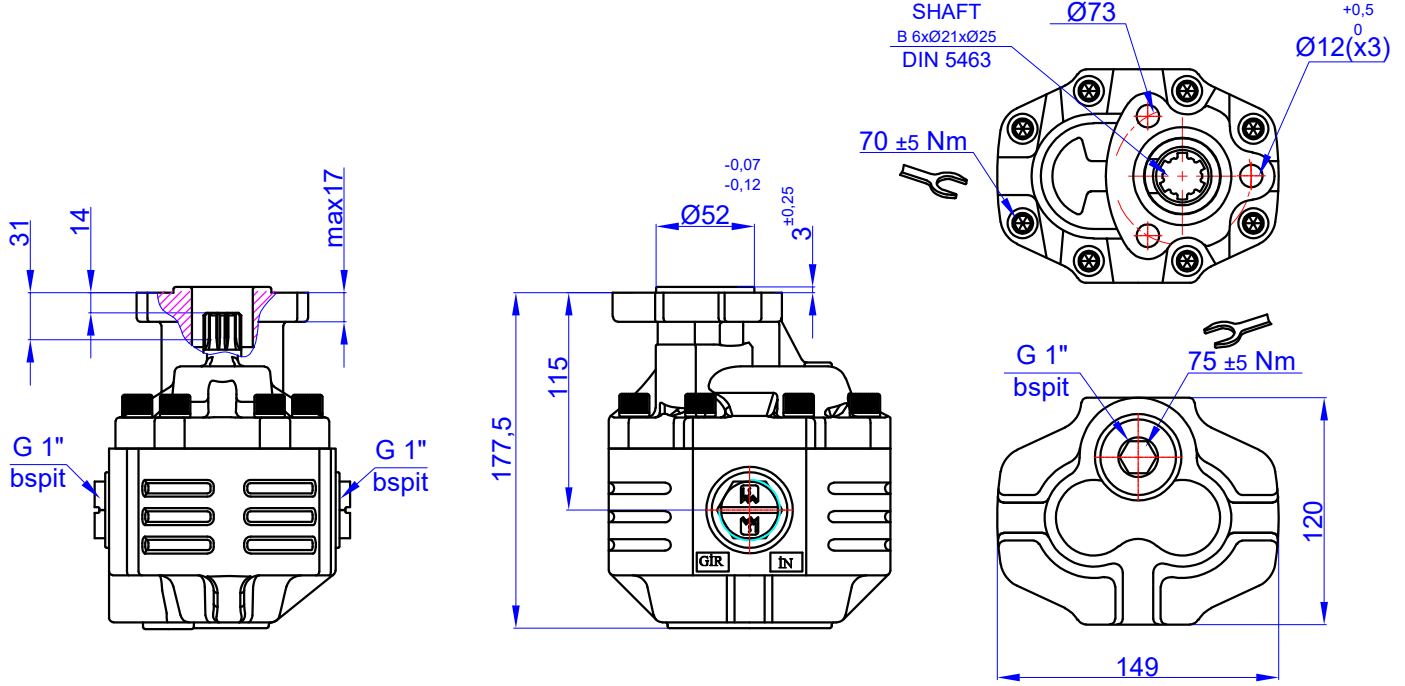

TEKNİK BİLGİLER / TECHNICAL DATA

Specifications		
Displacement	61	cm ³ /rev
Max. Peak Pressure (P3)	240	bar
Max. Intermittent Pressure (P2) (for tipping applications)	230	bar
Max. Continuous Pressure (P1)	210	bar
Max. Speed at Intermittent Press.	2000	min ⁻¹
Min. Speed at Intermittent Press.	300	min ⁻¹
Max. Speed at Continuous Press.	1700	min ⁻¹
Oil Temperature Range	-40 ~ 80	°C
Inlet Pressure Range (suction side)	0,7 ~ 3	bar
Recommended Oil Viscosity Range	12 ~ 100	mm ² /s (cSt)
Max. Starting Viscosity	750	mm ² /s (cSt)
Filtration :		
-Working Pressure < 200 bar	25	µm
-Working Pressure > 200 bar	10	µm
Connection :		
Min. Suction Hose Bore Diameter	-	inch
Weight	10,5	kg
Rust prevent oil applied shaft area		protect 12 months

Power and Torque					
Pressure (Bar)	50	100	150	200	240
Torque (Nm)	54	108	162	216	259

Power (kW)					
rpm / Bar	50	100	150	200	240
500	3	6	9	12	14
1000	6	12	17	23	28
1500	9	17	26	35	42
1700	10	20	29	39	47
2000	12	23	35	46	55

rpm (n/min)	Flow (L/min)
500	30
1000	60
1500	90
1700	102
2000	120

DIYAGRAMLAR / DIAGRAMS

Power-Pressure Graphic

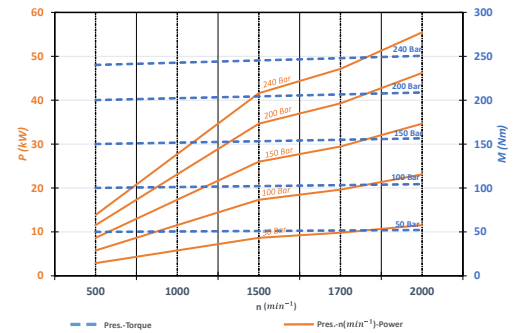

Flow-rpm Graphic

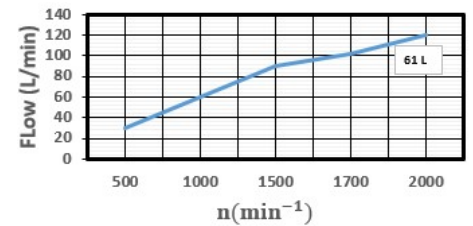

Torque-Pressure Graphic

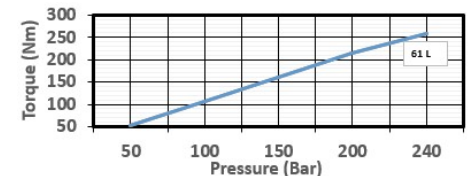

Pressure Definition

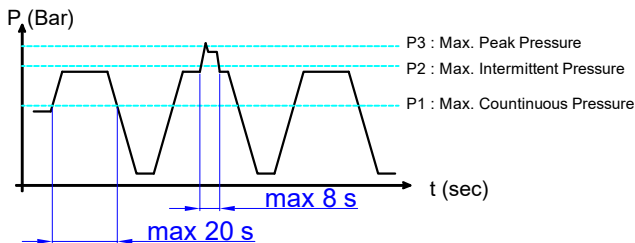

Hydraulic Pump Symbol

