

61 cc GEAR PUMP-ISO  
DPA 30-61 DIŞLI POMPA SAĞ / SOL

Product Code / Ürün Kodu : PDTD300610131  
Ref. No : 0002 PDTD300610132

CW  
CCW

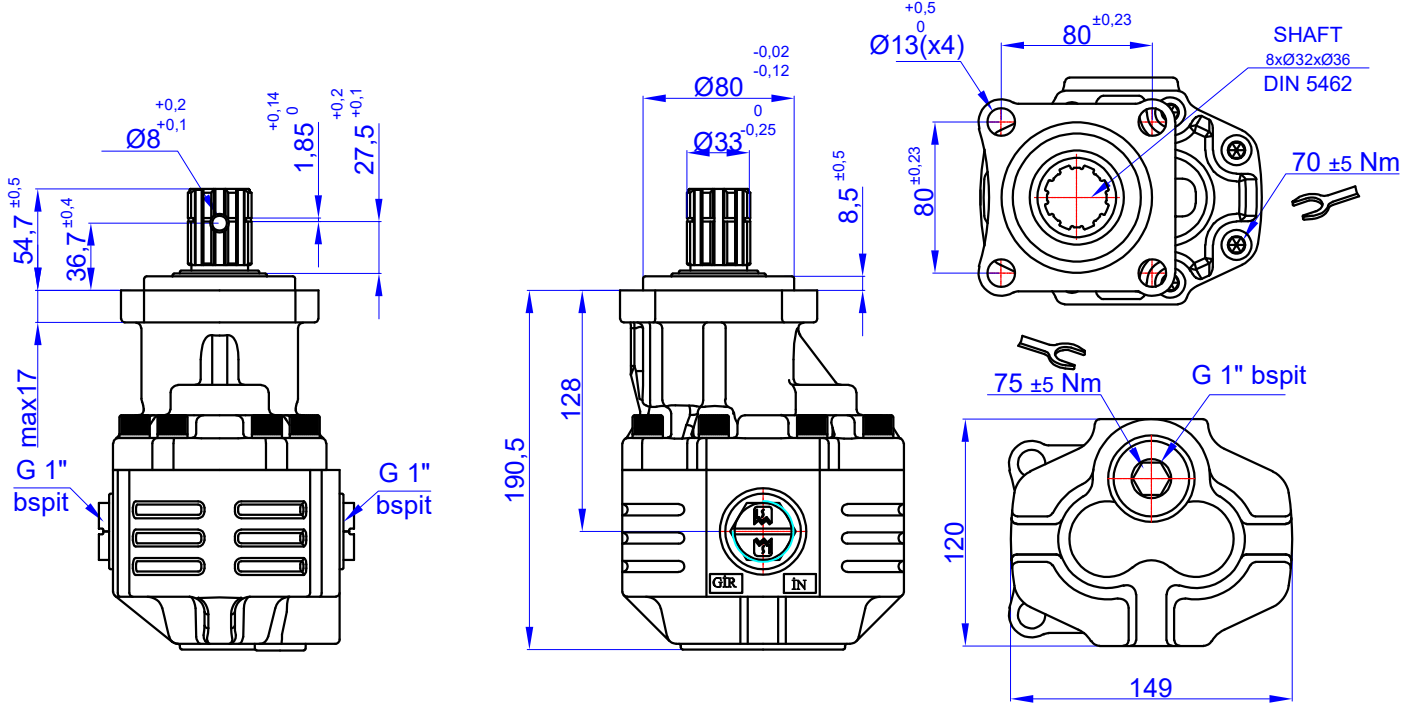

## TEKNIK BİLGİLER / TECHNICAL DATA

### Specifications

Displacement	61	cm <sup>3</sup> /rev
Max. Peak Pressure (P3)	240	bar
Max. Intermittent Pressure (P2) (for tipping applications)	230	bar
Max. Continuous Pressure (P1)	210	bar
Max. Speed at Intermittent Press.	2000	min <sup>-1</sup>
Min. Speed at Intermittent Press.	300	min <sup>-1</sup>
Max. Speed at Continuous Press.	1700	min <sup>-1</sup>
Oil Temperature Range	-40 ~ 80	°C
Inlet Pressure Range (suction side)	0,7 ~ 3	bar
Recommended Oil Viscosity Range	12 ~ 100	mm <sup>2</sup> /s (cSt)
Max. Starting Viscosity	750	mm <sup>2</sup> /s (cSt)
<b>Filtration :</b>		
-Working Pressure < 200 bar	25	µm
-Working Pressure > 200 bar	10	µm
<b>Connection :</b>		
Min. Suction Hose Bore Diameter	-	inch
Weight	13	kg
Rust prevent oil applied shaft area		protect 12 months

### Power and Torque

Pressure (Bar)	50	100	150	200	240
Torque (Nm)	54	108	162	216	259

### Power (kW)

rpm / Bar	50	100	150	200	240
500	3	6	9	12	14
1000	6	12	17	23	28
1500	9	17	26	35	42
1700	10	20	29	39	47
2000	12	23	35	46	55

rpm (n/min)	Flow (L/min)
500	30
1000	60
1500	90
1700	102
2000	120

## DIYAGRAMLAR / DIAGRAMS

### Power-Pressure Graphic

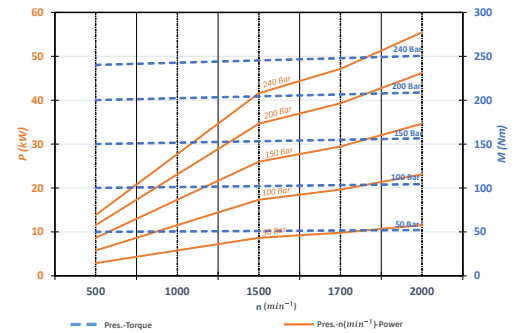

### Flow-rpm Graphic

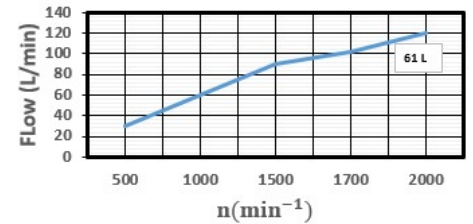

### Torque-Pressure Graphic

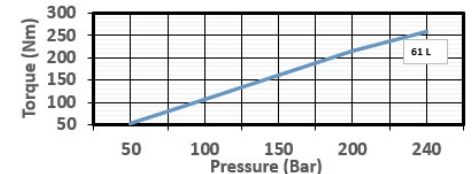

### Pressure Definition

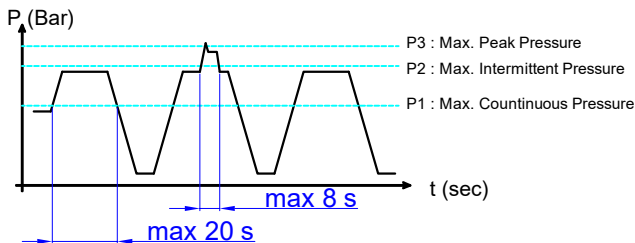

### Hydraulic Pump Symbol

