

82 cc GEAR PUMP-UNI  
DP 30-82 DİŞLİ POMPA SAĞ / SOL

Product Code / Ürün Kodu : PDTD300820011  
Ref. No : 0001 PDTD300820012

CW  
CCW

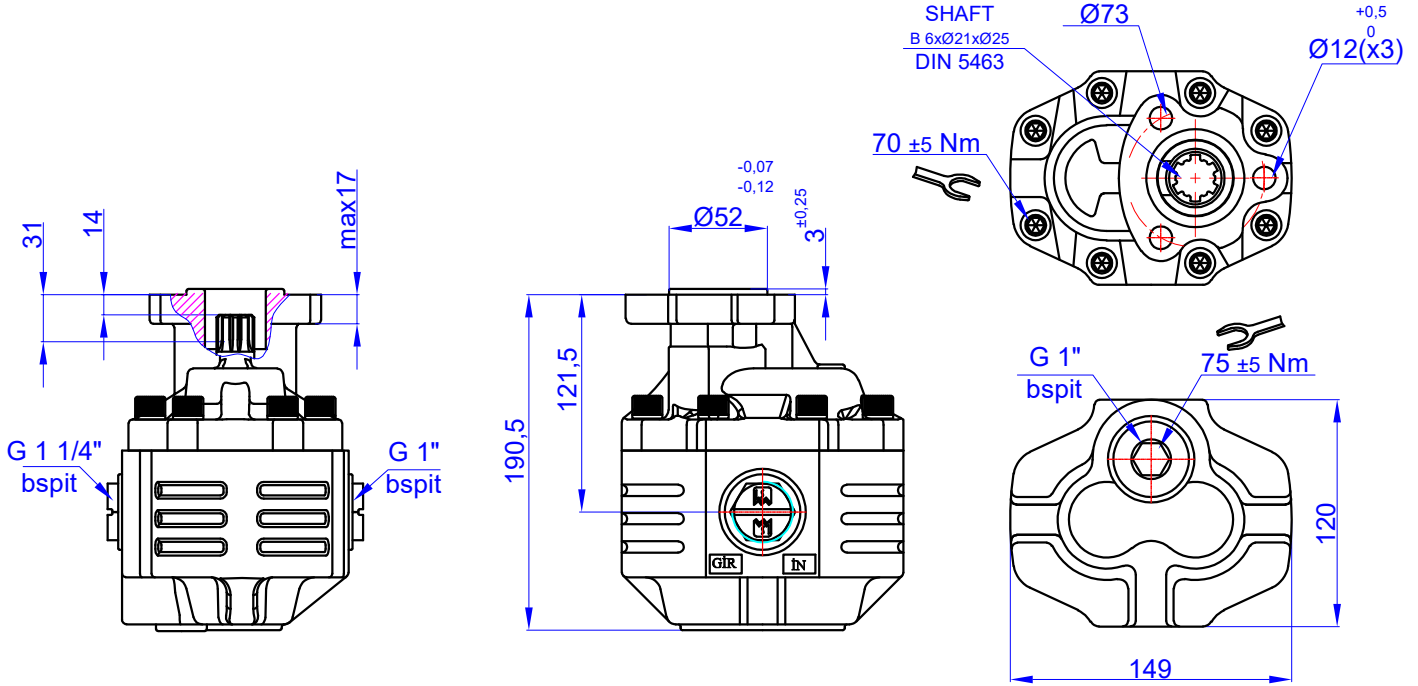

## TEKNİK BİLGİLER / TECHNICAL DATA

### Specifications

|   |          |                          |
|---|----------|--------------------------|
| Displacement  | 82       | cm <sup>3</sup> /rev     |
| Max. Peak Pressure (P3)                                       | 220      | bar                      |
| Max. Intermittent Pressure (P2)<br>(for tipping applications) | 210      | bar                      |
| Max. Continuous Pressure (P1)                                 | 180      | bar                      |
| Max. Speed at Intermittent Press.                             | 1800     | min <sup>-1</sup>        |
| Min. Speed at Intermittent Press.                             | 300      | min <sup>-1</sup>        |
| Max. Speed at Continuous Press.                               | 1500     | min <sup>-1</sup>        |
| Oil Temperature Range   | -40 ~ 80 | °C                       |
| Inlet Pressure Range (suction side)                           | 0,7 ~ 3  | bar                      |
| Recommended Oil Viscosity Range                               | 12 ~ 100 | mm <sup>2</sup> /s (cSt) |
| Max. Starting Viscosity                                       | 750      | mm <sup>2</sup> /s (cSt) |
| <b>Filtration :</b>   |          |                          |
| -Working Pressure < 200 bar                                   | 25       | µm                       |
| -Working Pressure > 200 bar                                   | 10       | µm                       |
| <b>Connection :</b>   |          |                          |
| Min. Suction Hose Bore Diameter                               | -        | inch                     |
| Weight  | 12       | kg                       |
| Rust prevent oil applied shaft area                           |          | protect 12 months        |

### Power and Torque

| Pressure (Bar) | 50 | 100 | 150 | 200 | 220 |
|----------------|----|-----|-----|-----|-----|
| Torque (Nm)    | 73 | 145 | 218 | 290 | 319 |

### Power (kW)

| rpm / Bar | 50 | 100 | 150 | 200 | 220 |
|-----------|----|-----|-----|-----|-----|
| 500       | 4  | 8   | 12  | 16  | 17  |
| 1000      | 8  | 16  | 23  | 31  | 34  |
| 1200      | 9  | 19  | 28  | 37  | 41  |
| 1500      | 12 | 23  | 35  | 47  | 51  |
| 1800      | 14 | 28  | 42  | 56  | 62  |

| rpm (n/min) | Flow (L/min) |
|-------------|--------------|
| 500         | 40           |
| 1000        | 80           |
| 1200        | 96           |
| 1500        | 121          |
| 1800        | 145          |

## DİYAGRAMLAR / DIAGRAMS

### Power-Pressure Graphic

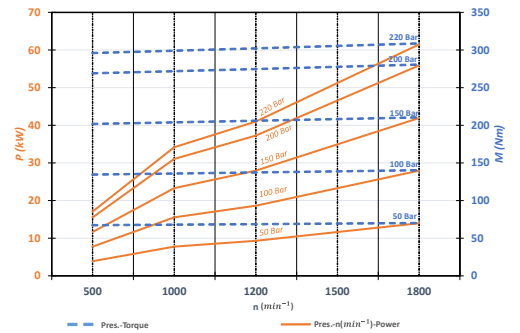

### Flow-rpm Graphic

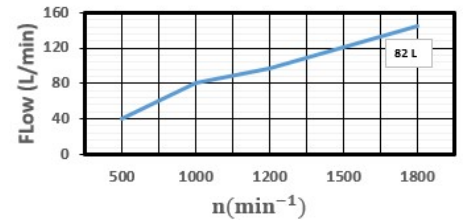

### Torque-Pressure Graphic

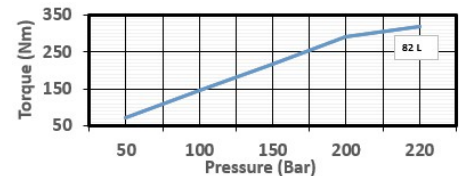

### Pressure Definition

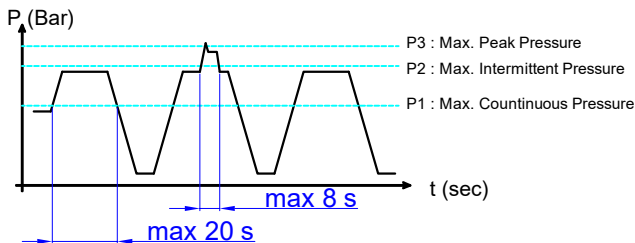

### Hydraulic Pump Symbol

