

51 cc BI-ROTATIONAL GEAR PUMP 4P-UNI
DP 30-51 T1 ÇİFT DÖNÜŞLÜ (4 PORTLU) DİŞLİ POMPA

Product Code / Ürün Kodu : PDCD3005100013
Ref. No : 0001

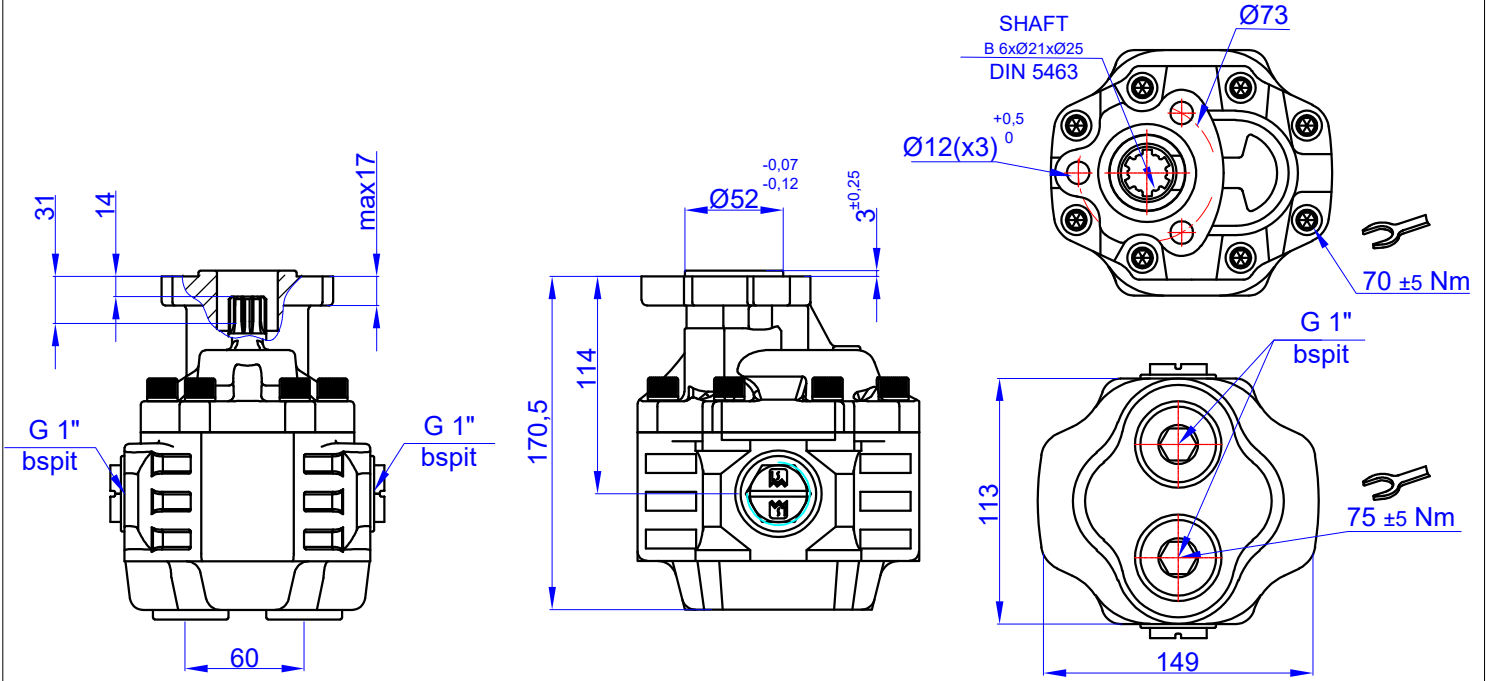

TEKNİK BİLGİLER / TECHNICAL DATA

Specifications

Displacement	51	cm ³ /rev
Max. Peak Pressure (P3)	250	bar
Max. Intermittent Pressure (P2) (for tipping applications)	240	bar
Max. Continuous Pressure (P1)	220	bar
Max. Speed at Intermittent Press.	2000	min ⁻¹
Min. Speed at Intermittent Press.	300	min ⁻¹
Max. Speed at Continuous Press.	1700	min ⁻¹
Oil Temperature Range	-40 ~ 80	°C
Inlet Pressure Range (suction side)	0,7 ~ 3	bar
Recommended Oil Viscosity Range	12 ~ 100	mm ² /s (cSt)
Max. Starting Viscosity	750	mm ² /s (cSt)
Filtration :		
-Working Pressure < 200 bar	25	µm
-Working Pressure > 200 bar	10	µm
Connection :		
Min. Suction Hose Bore Diameter	--	inch
Weight	10	kg
Rust prevent oil applied shaft area		protect 12 moths

Power and Torque

Pressure (Bar)	50	100	150	200	250
Torque (Nm)	45	90	135	180	225

Power (kW)

rpm / Bar	50	100	150	200	250
500	2	5	7	10	12
1000	5	10	14	19	24
1500	7	14	22	29	36
1700	8	16	25	33	41
2000	10	19	29	39	48

rpm (n/min)	Flow (L/min)
500	25
1000	50
1500	75
1700	85
2000	100

DİYAGRAMLAR / DIAGRAMS

Power-Pressure Graphic

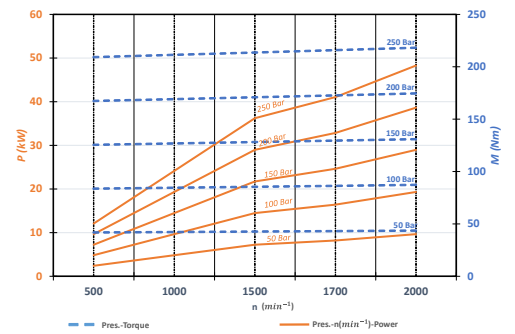

Flow-rpm Graphic

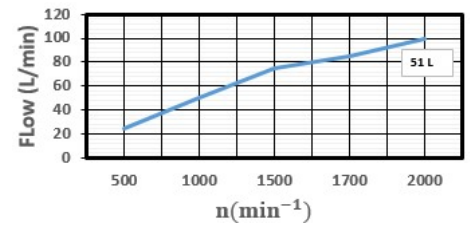

Torque-Pressure Graphic

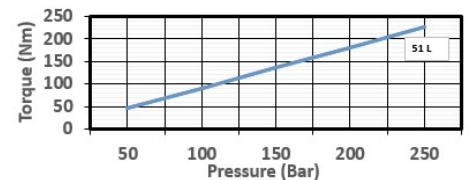

Pressure Definition

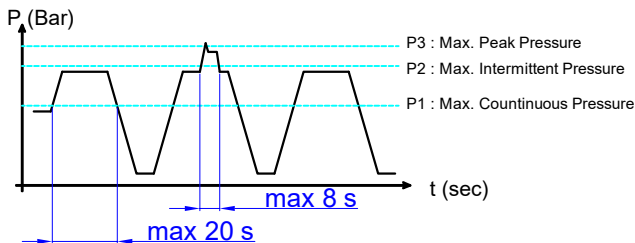

Hydraulic Pump Symbol

