

55 cc BI-ROTATIONAL GEAR PUMP-ISO  
DPA 30-55 ÇİFT DÖNÜŞLÜ (YAN G-Ç) DİŞLİ POMPA

Product Code / Ürün Kodu : PDCD3005520133  
Ref. No : 0001

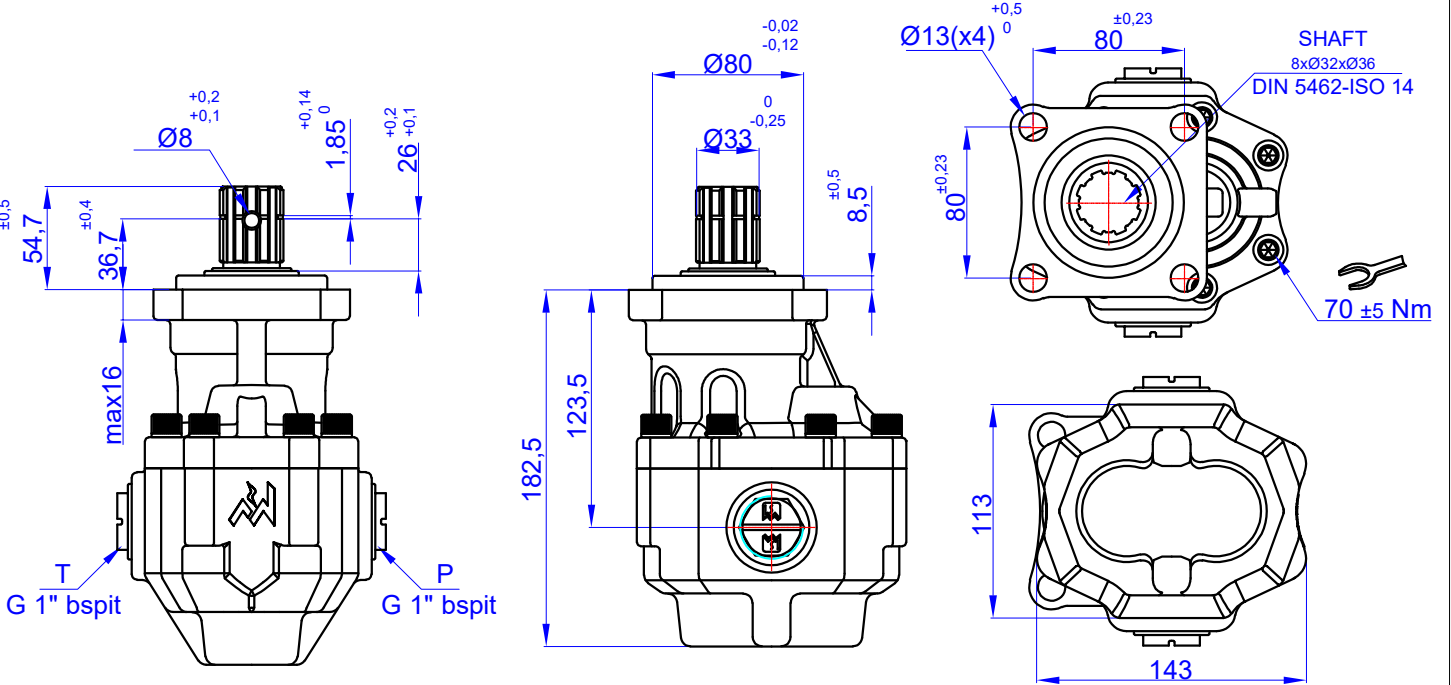

### TEKNİK BİLGİLER / TECHNICAL DATA

Specifications		
Displacement	55	cm <sup>3</sup> /rev
Max. Peak Pressure (P3)	250	bar
Max. Intermittent Pressure (P2) (for tipping applications)	240	bar
Max. Continuous Pressure (P1)	220	bar
Max. Speed at Intermittent Press.	2000	min <sup>-1</sup>
Min. Speed at Intermittent Press.	300	min <sup>-1</sup>
Max. Speed at Continuous Press.	1700	min <sup>-1</sup>
Oil Temperature Range	-40 ~ 80	°C
Inlet Pressure Range (suction side)	0,7 ~ 3	bar
Recommended Oil Viscosity Range	12 ~ 100	mm <sup>2</sup> /s (cSt)
Max. Starting Viscosity	750	mm <sup>2</sup> /s (cSt)
<b>Filtration :</b>		
-Working Pressure < 200 bar	25	µm
-Working Pressure > 200 bar	10	µm
<b>Connection :</b>		
Min. Suction Hose Bore Diameter	-	inch
Weight	11	kg
Rust prevent oil applied shaft area	protect 12 moths	

Power and Torque					
Pressure (Bar)	50	100	150	200	250
Torque (Nm)	49	97	146	195	243

Power (kW)						
rpm / Bar	50	100	150	200	250	
500	3	5	8	10	13	
1000	5	10	16	21	26	
1500	8	16	23	31	39	
1700	9	18	27	35	44	
2000	10	21	31	42	52	

rpm (n/min)	Flow (L/min)
500	27
1000	54
1500	81
1700	92
2000	108

### DİYAGRAMLAR / DIAGRAMS

#### Power-Pressure Graphic

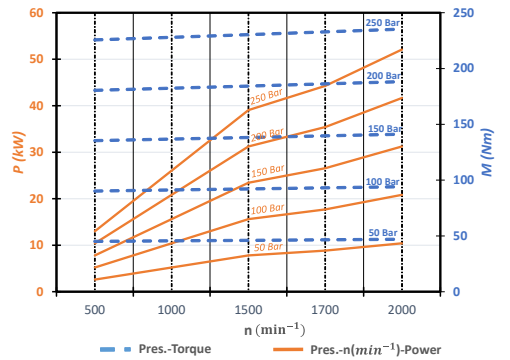

#### Flow-rpm Graphic

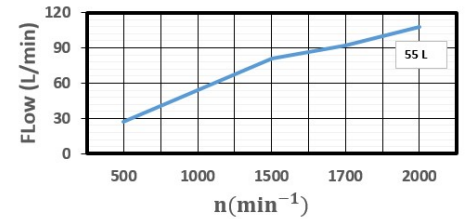

#### Torque-Pressure Graphic

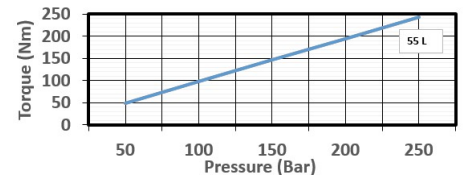

#### Pressure Definition

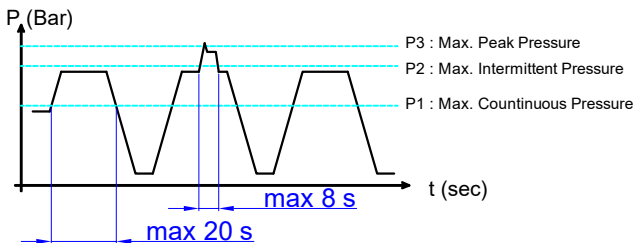

#### Hydraulic Pump Symbol

