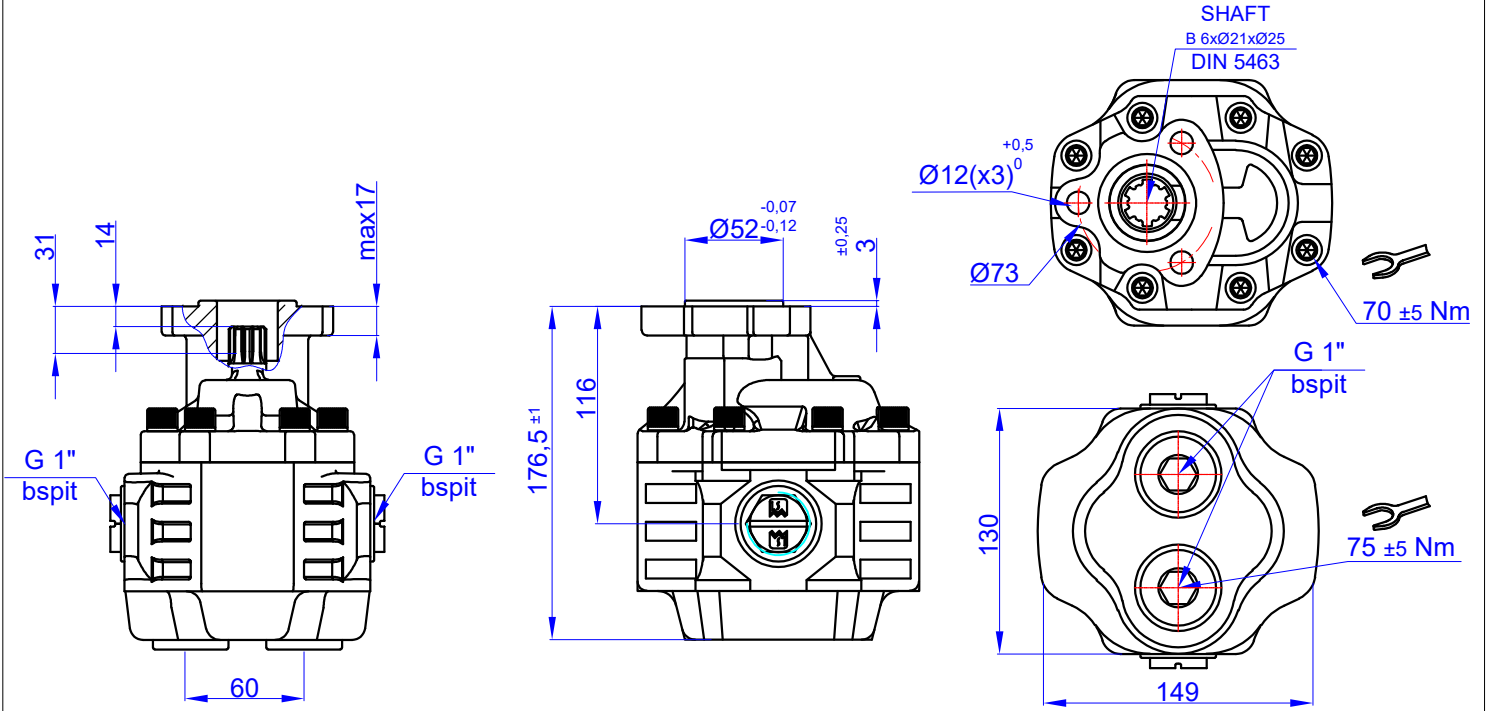

61 cc BI-ROTATIONAL GEAR PUMP 4P-UNI
 DP 30-61 T1 ÇİFT DÖNÜŞLÜ (4 PORTLU) DİŞLİ POMPA

Product Code / Ürün Kodu : PDCD3006100013
 Ref. No : 0001

TEKNİK BİLGİLER / TECHNICAL DATA
Specifications

Displacement	61	cm ³ /rev
Max. Peak Pressure (P1)	240	bar
Max. Intermittent Pressure (P2) (for tipping applications)	230	bar
Max. Continuous Pressure (P3)	210	bar
Max. Speed Without Load	-	min ⁻¹
Max. Speed at Intermittent Press.	2000	min ⁻¹
Min. Speed at Intermittent Press.	300	min ⁻¹
Max. Speed at Continuous Press.	1700	min ⁻¹
Oil Temperature Range	-40 ~ 80	°C
Inlet Pressure Range (suction side)	0,7 ~ 3	bar
Recommended Oil Viscosity Range	12 ~ 100	mm ² /s (cSt)
Max. Starting Viscosity	750	mm ² /s (cSt)
Filtration :		
Working Pressure < 200 bar	25	µm
Working Pressure > 200 bar	10	µm
Connection :		
Min. Suction Hose Bore Diameter	---	inch
Weight	12	kg
Rust prevent oil applied shaft area	protect 12 moths	

Power and Torque

Pressure (Bar)	50	100	150	200	240
Torque (Nm)	54	108	162	216	259

Power (kW)

rpm / Bar	50	100	150	200	240
500	3	6	9	12	14
1000	6	12	17	23	28
1500	9	17	26	35	42
1700	10	20	29	39	47
2000	12	23	35	46	55

rpm (n/min)	Flow (L/min)
500	30
1000	60
1500	90
1700	102
2000	120

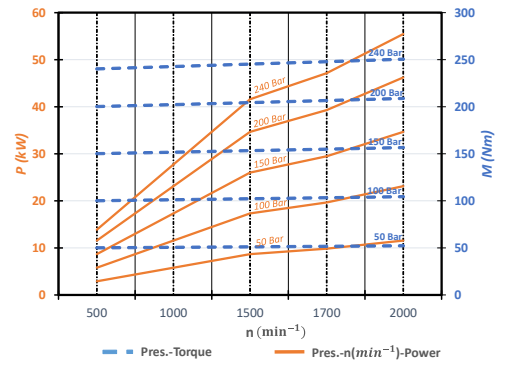
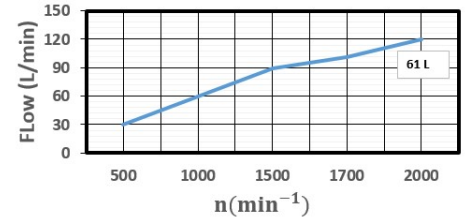
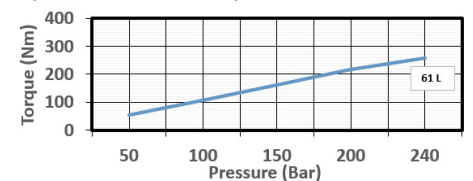
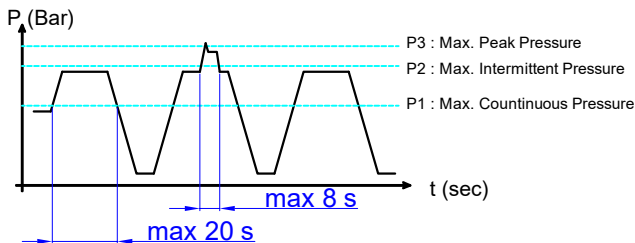
DİYAGRAMLAR / DIAGRAMS
Power-Pressure Graphic

Flow-rpm Graphic

Torque-Pressure Graphic

Pressure Definition

Hydraulic Pump Symbol
