

65 cc BI-ROTATIONAL GEAR PUMP-ISO  
DPA 30-65 ÇİFT DÖNÜŞLÜ (ARKA G-Ç) DIŞLI POMPA

Product Code / Ürün Kodu : PDCD3006510133  
Ref. No : 0001

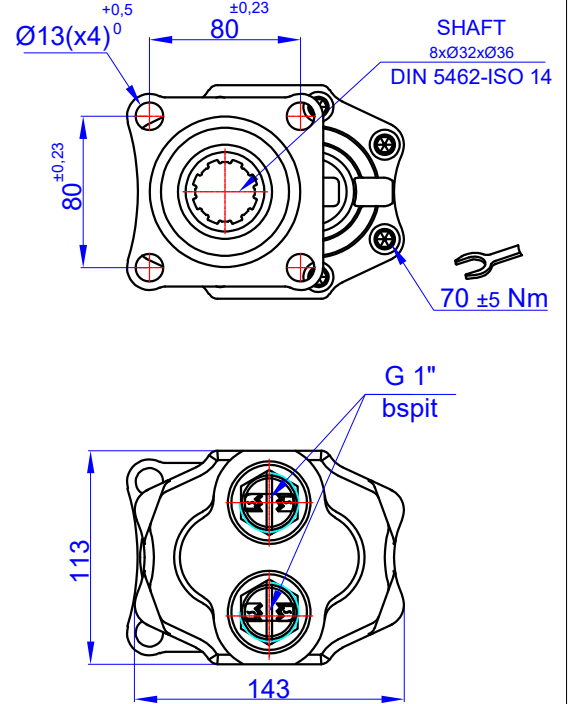
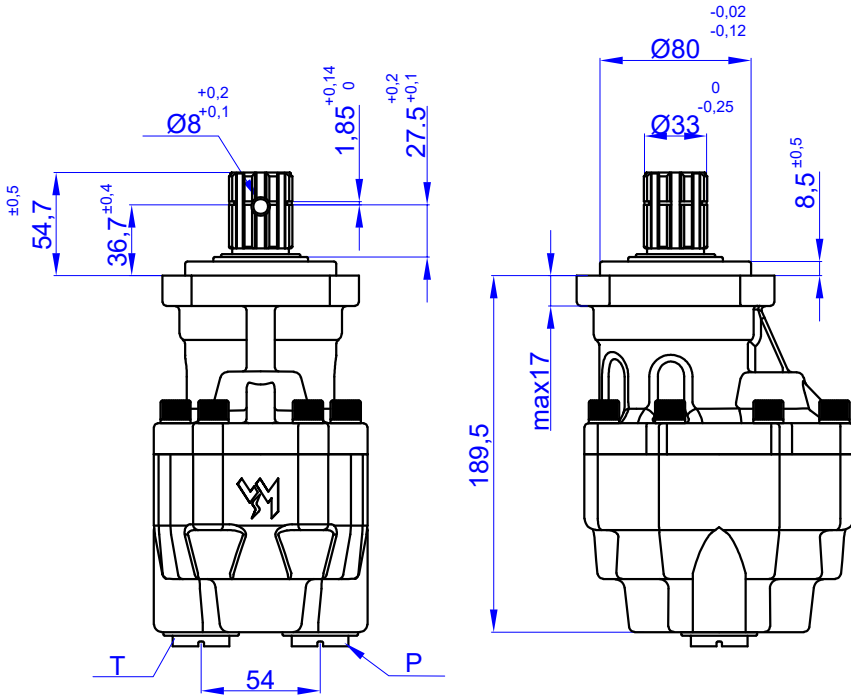

### TEKNİK BİLGİLER / TECHNICAL DATA

Specifications		
Displacement	65	cm <sup>3</sup> /rev
Max. Peak Pressure (P3)	240	bar
Max. Intermittent Pressure (P2) (for tipping applications)	230	bar
Max. Continuous Pressure (P1)	210	bar
Max. Speed at Intermittent Press.	2000	min <sup>-1</sup>
Min. Speed at Intermittent Press.	300	min <sup>-1</sup>
Max. Speed at Continuous Press.	1700	min <sup>-1</sup>
Oil Temperature Range	-40 ~ 80	°C
Inlet Pressure Range (suction side)	0,7 ~ 3	bar
Recommended Oil Viscosity Range	12 ~ 100	mm <sup>2</sup> /s (cSt)
Max. Starting Viscosity	750	mm <sup>2</sup> /s (cSt)
<b>Filtration :</b>		
-Working Pressure < 200 bar	25	µm
-Working Pressure > 200 bar	10	µm
<b>Connection :</b>		
Min. Suction Hose Bore Diameter	--	inch
Weight	11.5	kg
Rust prevent oil applied shaft area	protect 12 moths	

Power and Torque					
Pressure (Bar)	50	100	150	200	240
Torque (Nm)	57	115	172	230	276

Power (kW)						
rpm / Bar	50	100	150	200	240	
500	3	6	9	12	15	
1000	6	12	18	25	30	
1500	9	18	28	37	44	
1700	10	21	31	42	50	
2000	12	25	37	49	59	

rpm (n/min)	Flow (L/min)
500	32
1000	64
1500	96
1700	108
2000	127

### DİYAGRAMLAR / DIAGRAMS

#### Power-Pressure Graphic

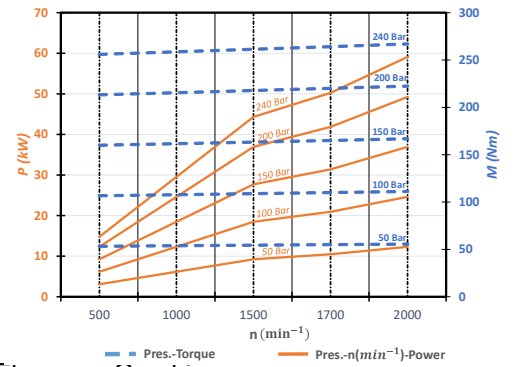

#### Flow-rpm Graphic

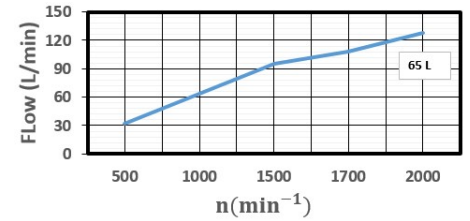

#### Torque-Pressure Graphic

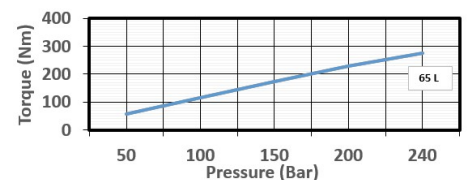

#### Pressure Definition

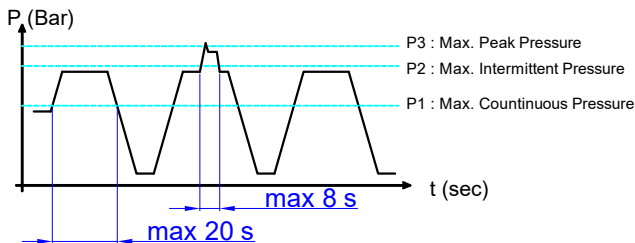

#### Hydraulic Pump Symbol

