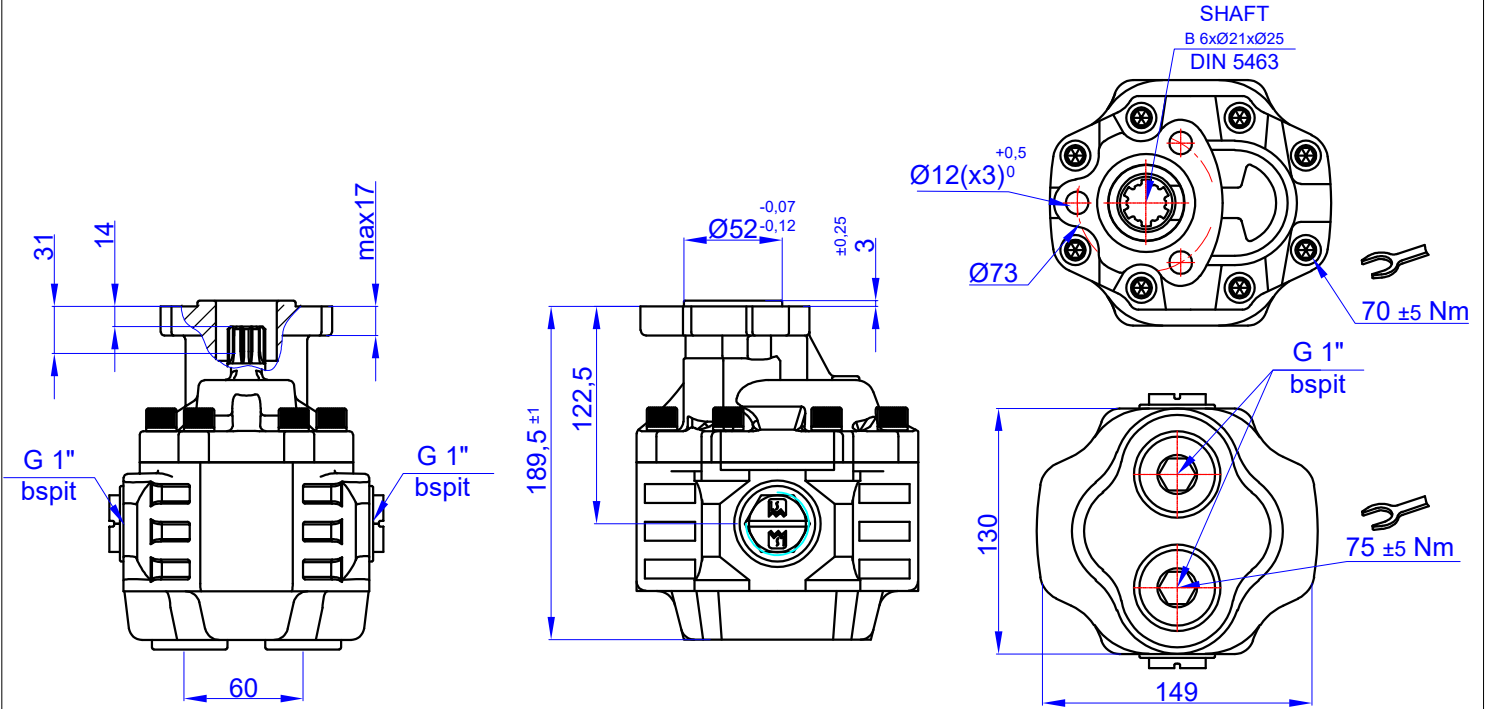

82 cc BI-ROTATIONAL GEAR PUMP 4P-UNI  
 DP 30-82 T1 ÇİFT DÖNÜŞLÜ (4 PORTLU) DİŞLİ POMPA

Product Code / Ürün Kodu : PDCD3008200013  
 Ref. No : 0001

**TEKNİK BİLGİLER / TECHNICAL DATA**
**Specifications**

Displacement	82	cm <sup>3</sup> /rev
Max. Peak Pressure (P3)	220	bar
Max. Intermittent Pressure (P2) (for tipping applications)	210	bar
Max. Continuous Pressure (P1)	180	bar
Max. Speed at Intermittent Press.	1800	min <sup>-1</sup>
Min. Speed at Intermittent Press.	300	min <sup>-1</sup>
Max. Speed at Continuous Press.	1500	min <sup>-1</sup>
Oil Temperature Range	-40 ~ 80	°C
Inlet Pressure Range (suction side)	0,7 ~ 3	bar
Recommended Oil Viscosity Range	12 ~ 100	mm <sup>2</sup> /s (cSt)
Max. Starting Viscosity	750	mm <sup>2</sup> /s (cSt)
<b>Filtration :</b>		
-Working Pressure < 200 bar	25	µm
-Working Pressure > 200 bar	10	µm
<b>Connection :</b>		
Min. Suction Hose Bore Diameter	--	inch
Weight	13	kg
Rust prevent oil applied shaft area	protect 12 moths	

**Power and Torque**

Pressure (Bar)	50	100	150	200	220
Torque (Nm)	73	145	218	290	319

**Power (kW)**

rpm / Bar	50	100	150	200	220
500	4	8	12	16	17
1000	8	16	23	31	34
1200	9	19	28	37	41
1500	12	23	35	47	51
1800	14	28	42	56	62

**rpm (n/min) Flow (L/min)**

500	40
1000	80
1200	96
1500	121
1800	145

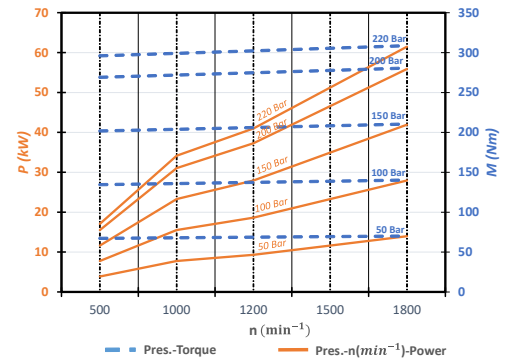
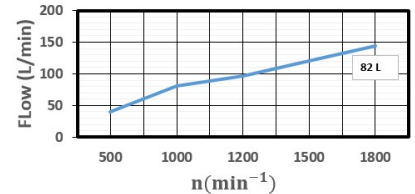
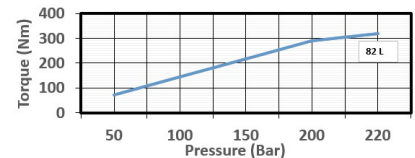
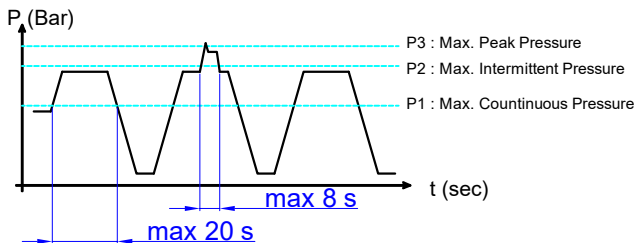
**DİYAGRAMLAR / DIAGRAMS**
**Power-Pressure Graphic**

**Flow-rpm Graphic**

**Torque-Pressure Graphic**

**Pressure Definition**

**Hydraulic Pump Symbol**
