

75 cc BI-ROTATIONAL GEAR PUMP-UNI  
DP 35-75 ÇİFT DÖNÜŞLÜ DIŞLI POMPA

Product Code / Ürün Kodu : PDCD3507510013  
Ref. No : 0001

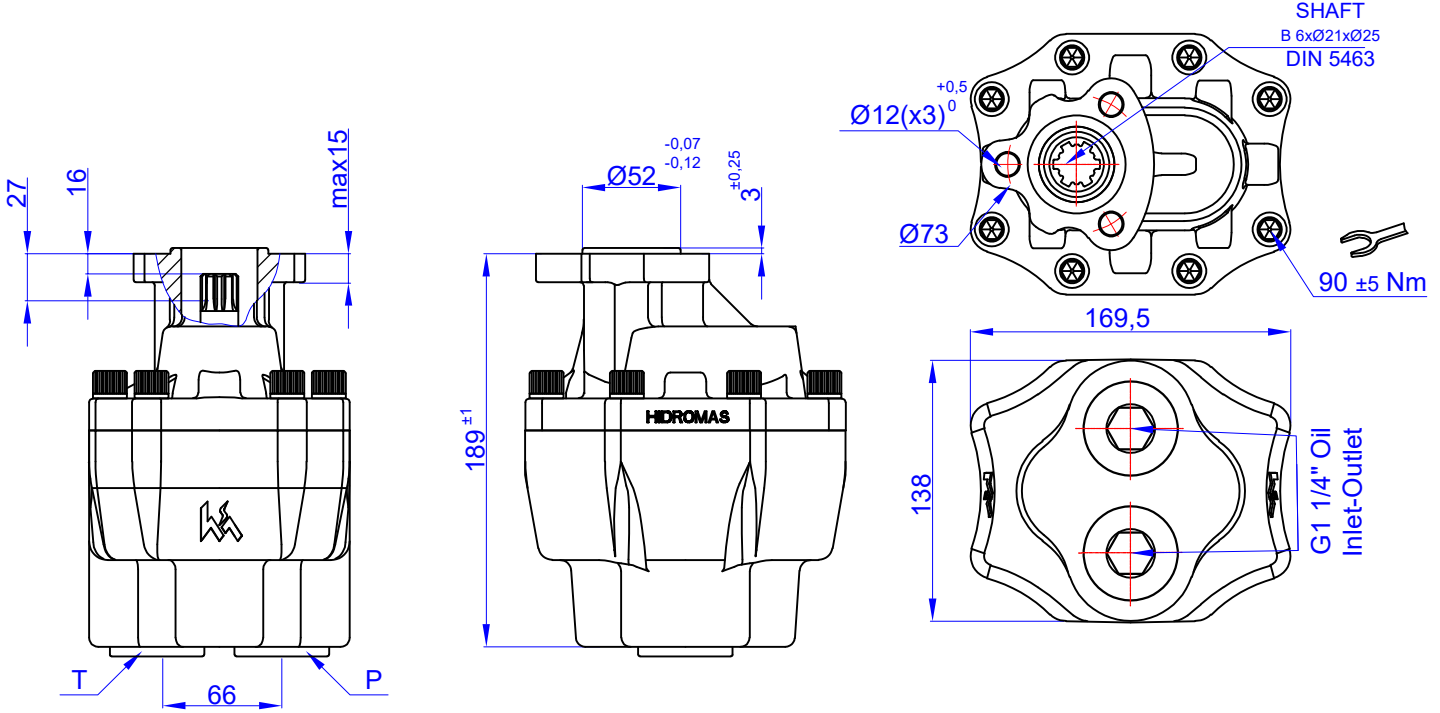

### TEKNIK BİLGİLER / TECHNICAL DATA

#### Specifications

Displacement	75	cm <sup>3</sup> /rev
Max. Peak Pressure (P3)	260	bar
Max. Intermittent Pressure (P2) (for tipping applications)	230	bar
Max. Continuous Pressure (P1)	210	bar
Max. Speed at Intermittent Press.	2000	min <sup>-1</sup>
Min. Speed at Intermittent Press.	300	min <sup>-1</sup>
Max. Speed at Continuous Press.	1500	min <sup>-1</sup>
Oil Temperature Range	-40 ~ 80	°C
Inlet Pressure Range (suction side)	0,7 ~ 3	bar
Recommended Oil Viscosity Range	12 ~ 100	mm <sup>2</sup> /s (cSt)
Max. Starting Viscosity	750	mm <sup>2</sup> /s (cSt)
<b>Filtration :</b>		
-Working Pressure < 200 bar	25	µm
-Working Pressure > 200 bar	10	µm
<b>Connection :</b>		
Min. Suction Hose Bore Diameter	--	inch
Weight	15	kg
Rust prevent oil applied shaft area	protect 12 moths	

#### Power and Torque

Pressure (Bar)	50	100	150	200	260
Torque (Nm)	66	133	199	265	345

#### Power (kW)

rpm / Bar	50	100	150	200	260
500	4	7	11	14	18
1000	7	14	21	28	37
1500	11	21	32	43	55
1700	12	24	36	48	63
2000	14	28	43	57	74

rpm (n/min)	Flow (L/min)
500	37
1000	74
1500	110
1700	125
2000	147

### DİYAGRAMLAR / DIAGRAMS

#### Power-Pressure Graphic

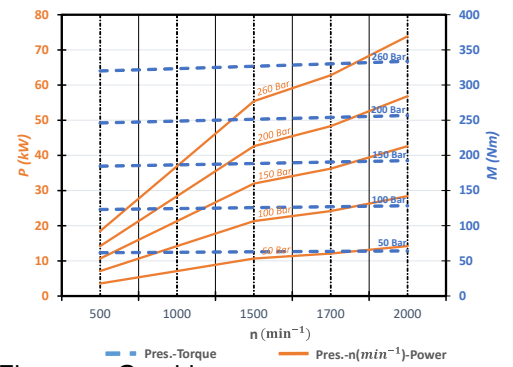

#### Flow-rpm Graphic

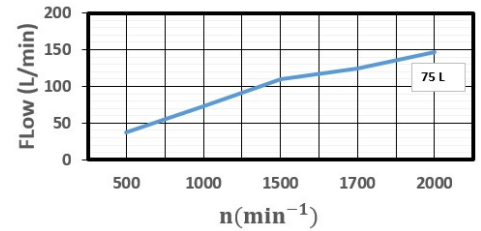

#### Torque-Pressure Graphic

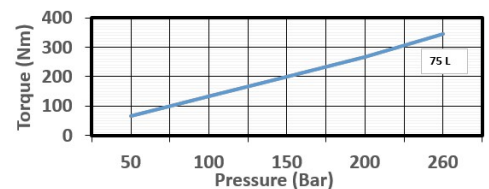

#### Pressure Definition

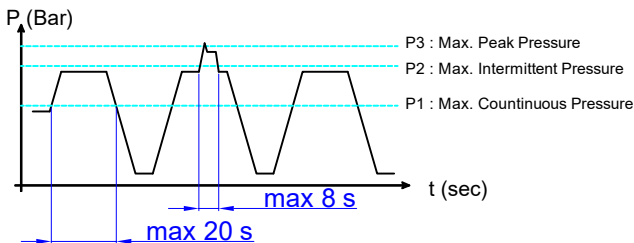

#### Hydraulic Pump Symbol

