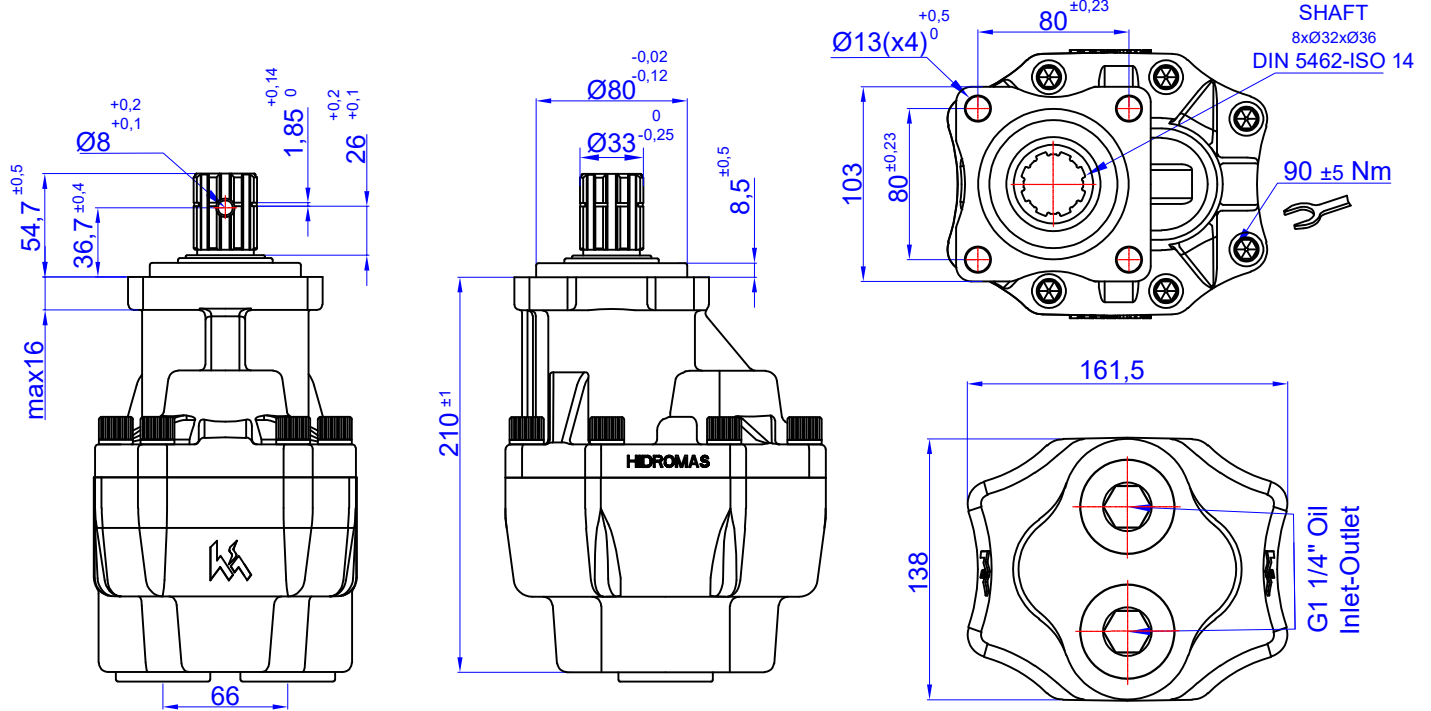

90 cc BI-ROTATIONAL GEAR PUMP DM-ISO  
 DPA 35-90 ÇİFT DÖNÜŞLÜ (DM) DIŞLI POMPA

Product Code / Ürün Kodu : PDCD3509040133  
 Ref. No : 0001

**TEKNİK BİLGİLER / TECHNICAL DATA**
**Specifications**

Displacement	90	cm <sup>3</sup> /rev
Max. Peak Pressure (P3)	265	bar
Max. Intermittent Pressure (P2) (for tipping applications)	250	bar
Max. Continuous Pressure (P1)	230	bar
Max. Speed at Intermittent Press.	2000	min <sup>-1</sup>
Min. Speed at Intermittent Press.	300	min <sup>-1</sup>
Max. Speed at Continuous Press.	1500	min <sup>-1</sup>
Oil Temperature Range	-40 ~ 80	°C
Inlet Pressure Range (suction side)	0,7 ~ 3	bar
Recommended Oil Viscosity Range	12 ~ 100	mm <sup>2</sup> /s (cSt)
Max. Starting Viscosity	750	mm <sup>2</sup> /s (cSt)
<b>Filtration :</b>		
-Working Pressure < 200 bar	25	µm
-Working Pressure > 200 bar	10	µm
<b>Connection :</b>		
Min. Suction Hose Bore Diameter	--	inch
Weight	16.5	kg
Rust prevent oil applied shaft area	protect 12 months	

**Power and Torque**

Pressure (Bar)	50	100	150	200	265
Torque (Nm)	80	159	239	318	422

**Power (kW)**

rpm / Bar	50	100	150	200	265
500	4	9	13	17	23
1000	9	17	26	34	45
1500	13	26	38	51	68
1700	14	29	43	58	77
2000	17	34	51	68	90

**rpm (n/min) Flow (L/min)**

rpm (n/min)	Flow (L/min)
500	44
1000	88
1500	132
1700	150
2000	176

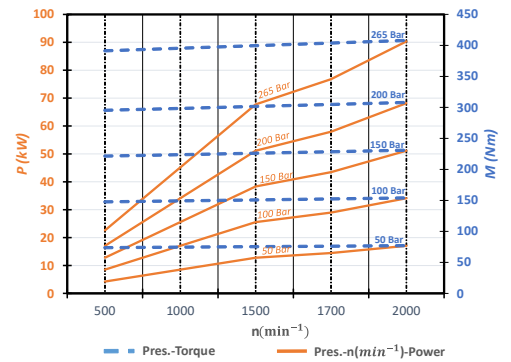
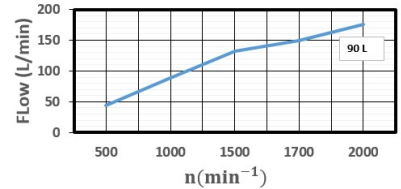
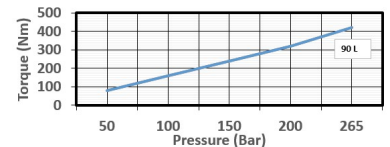
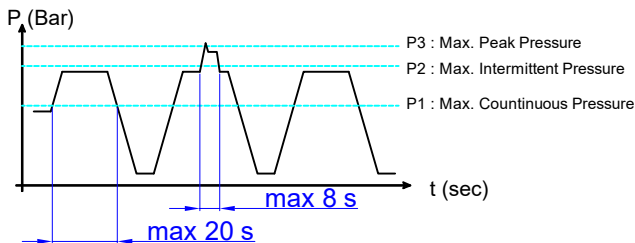
**DİYAGRAMLAR / DIAGRAMS**
**Power-Pressure Graphic**

**Flow-rpm Graphic**

**Torque-Pressure Graphic**

**Pressure Definition**

**Hydraulic Pump Symbol**
