

125 cc BI-ROTATIONAL GEAR PUMP-ISO
DPA 35-125 ÇİFT DÖNÜŞLÜ DİŞLİ POMPA

Product Code / Ürün Kodu : PDCD3512510133
Ref. No : 0003

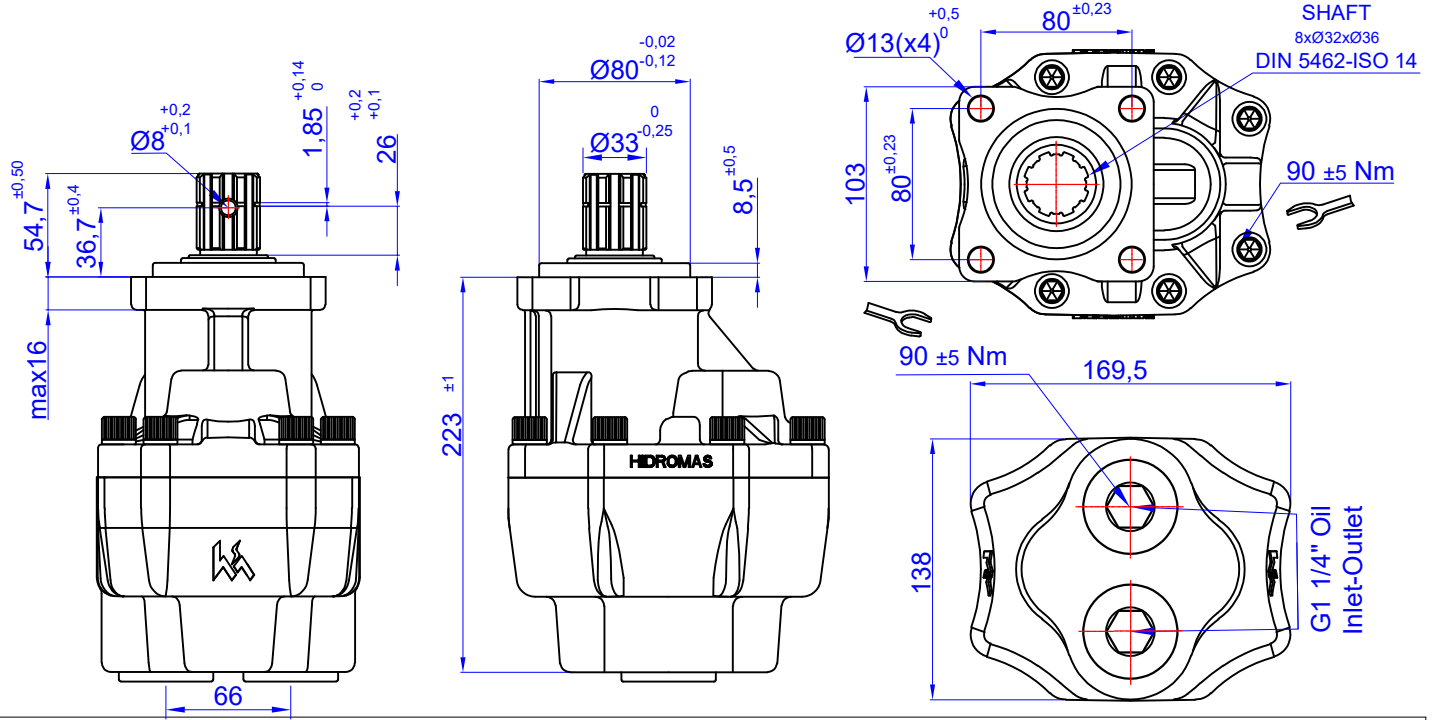

TEKNİK BİLGİLER / TECHNICAL DATA

Specifications

Displacement	125	cm ³ /rev
Max. Peak Pressure (P3)	230	bar
Max. Intermittent Pressure (P2) (for tipping applications)	210	bar
Max. Continuous Pressure (P1)	200	bar
Max. Speed at Intermittent Press.	1900	min ⁻¹
Min. Speed at Intermittent Press.	300	min ⁻¹
Max. Speed at Continuous Press.	1400	min ⁻¹
Oil Temperature Range	-40 ~ 80	°C
Inlet Pressure Range (suction side)	0,7 ~ 3	bar
Recommended Oil Viscosity Range	12 ~ 100	mm ² /s (cSt)
Max. Starting Viscosity	750	mm ² /s (cSt)
Filtration :		
-Working Pressure < 200 bar	25	µm
-Working Pressure > 200 bar	10	µm
Connection :		
Min. Suction Hose Bore Diameter	--	inch
Weight	20,5	kg
Rust prevent oil applied shaft area	protect 12 months	

Power and Torque

Pressure (Bar)	50	100	150	200	230
Torque (Nm)	111	221	332	442	508

Power (kW)

rpm / Bar	50	100	150	200	230
500	6	12	18	24	27
1000	12	24	36	47	54
1200	14	28	43	57	65
1400	17	33	50	66	76
1900	22	45	67	90	103

rpm (n/min)	Flow (L/min)
500	61
1000	123
1200	147
1400	172
1900	233

DİYAGRAMLAR / DIAGRAMS

Power-Pressure Graphic

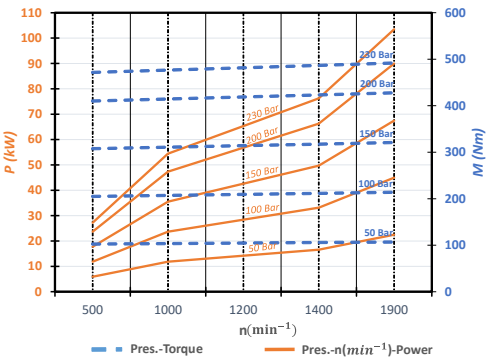

Flow-rpm Graphic

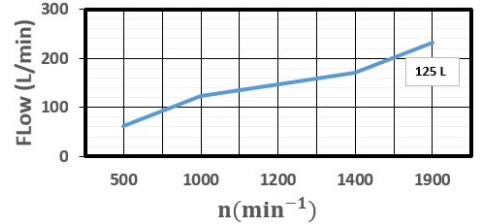

Torque-Pressure Graphic

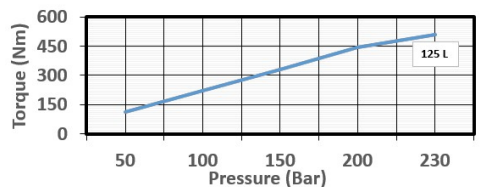

Pressure Definition

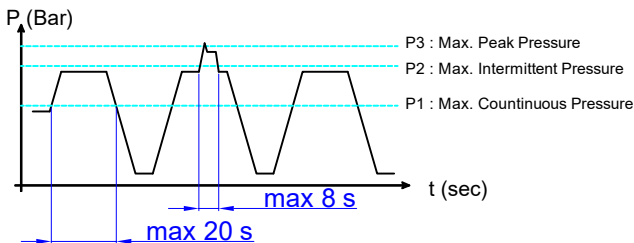

Hydraulic Pump Symbol

