

133 cc GEAR PUMP-UNI
DP 40-133 DİŞLİ POMPA SAĞ / SOL

Product Code / Ürün Kodu : PDTD401330011
Ref. No:R-0003 / L-0001 PDTD401330012

CW
CCW

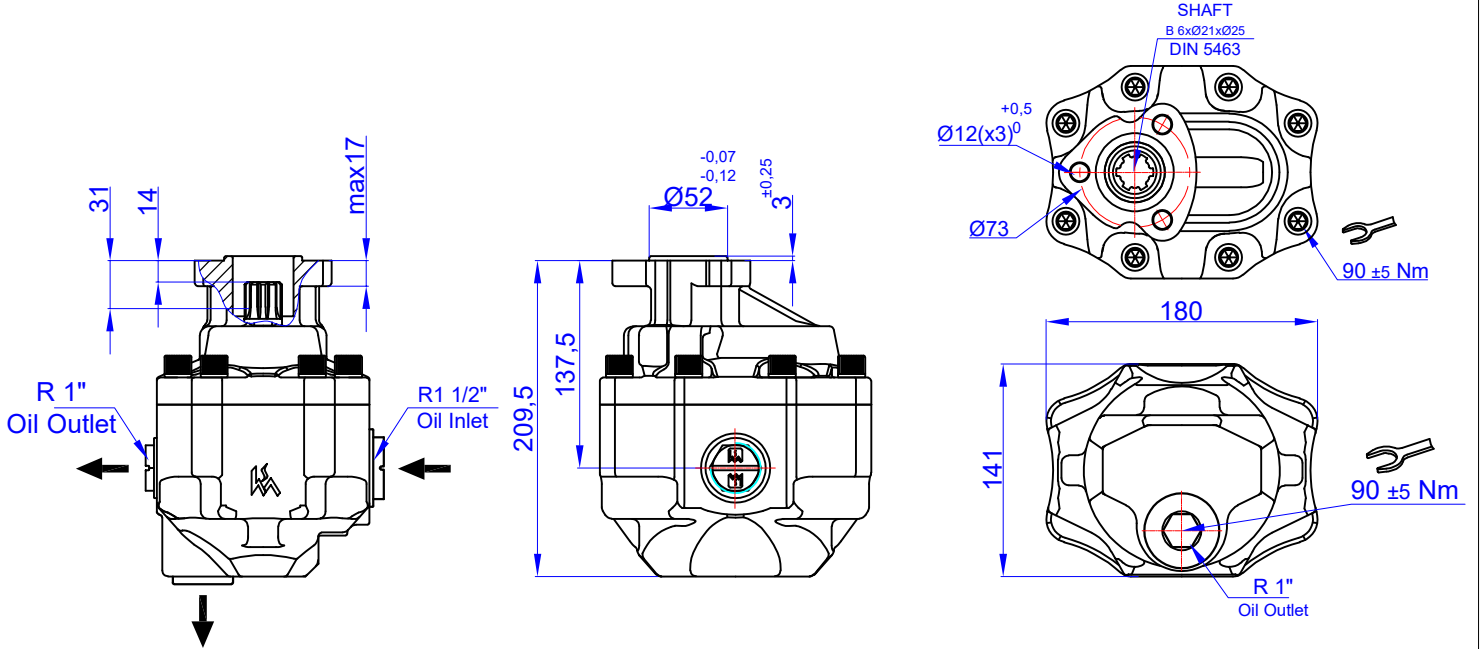

TEKNİK BİLGİLER / TECHNICAL DATA

Specifications

Displacement	133	cm ³ /rev
Max. Peak Pressure (P3)	230	bar
Max. Intermittent Pressure (P2) (for tipping applications)	220	bar
Max. Continuous Pressure (P1)	200	bar
Max. Speed at Intermittent Press.	2000	min ⁻¹
Min. Speed at Intermittent Press.	300	min ⁻¹
Max. Speed at Continuous Press.	1700	min ⁻¹
Oil Temperature Range	-40 ~ 80	°C
Inlet Pressure Range (suction side)	0,7 ~ 3	bar
Recommended Oil Viscosity Range	12 ~ 100	mm ² /s (cSt)
Max. Starting Viscosity	750	mm ² /s (cSt)
Filtration :		
-Working Pressure < 200 bar	25	µm
-Working Pressure > 200 bar	10	µm
Connection :		
Min. Suction Hose Bore Diameter	--	inch
Weight	20,5	kg
Rust prevent oil applied shaft area	protect 12 moths	

Power and Torque

Pressure (Bar)	50	100	150	200	230
Torque (Nm)	118	235	353	470	541

Power (kW)

rpm / Bar	50	100	150	200	230
500	6	13	19	25	29
1000	13	25	38	50	58
1500	19	38	57	76	87
1700	21	43	64	86	98
2000	25	50	76	101	116

rpm (n/min)	Flow (L/min)
500	65
1000	130
1500	196
1700	222
2000	261

DİYAGRAMLAR / DIAGRAMS

Power-Pressure Graphic

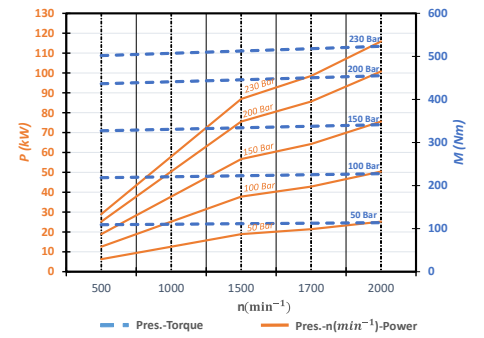

Flow-rpm Graphic

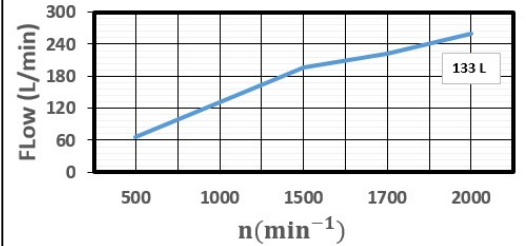

Torque-Pressure Graphic

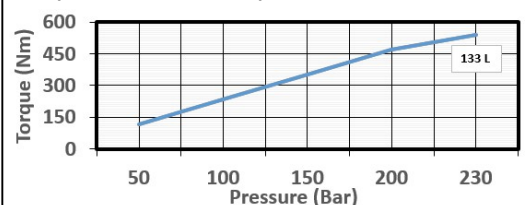

Pressure Definition

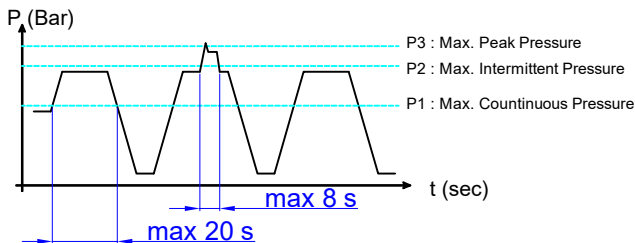

Hydraulic Pump Symbol

