

151 cc GEAR PUMP-UNI
DP 40-151 DİŞLİ POMPA SAĞ / SOL

Product Code / Ürün Kodu : PDTD401510011
Ref. No:0002 PDTD401510012

CW
CCW

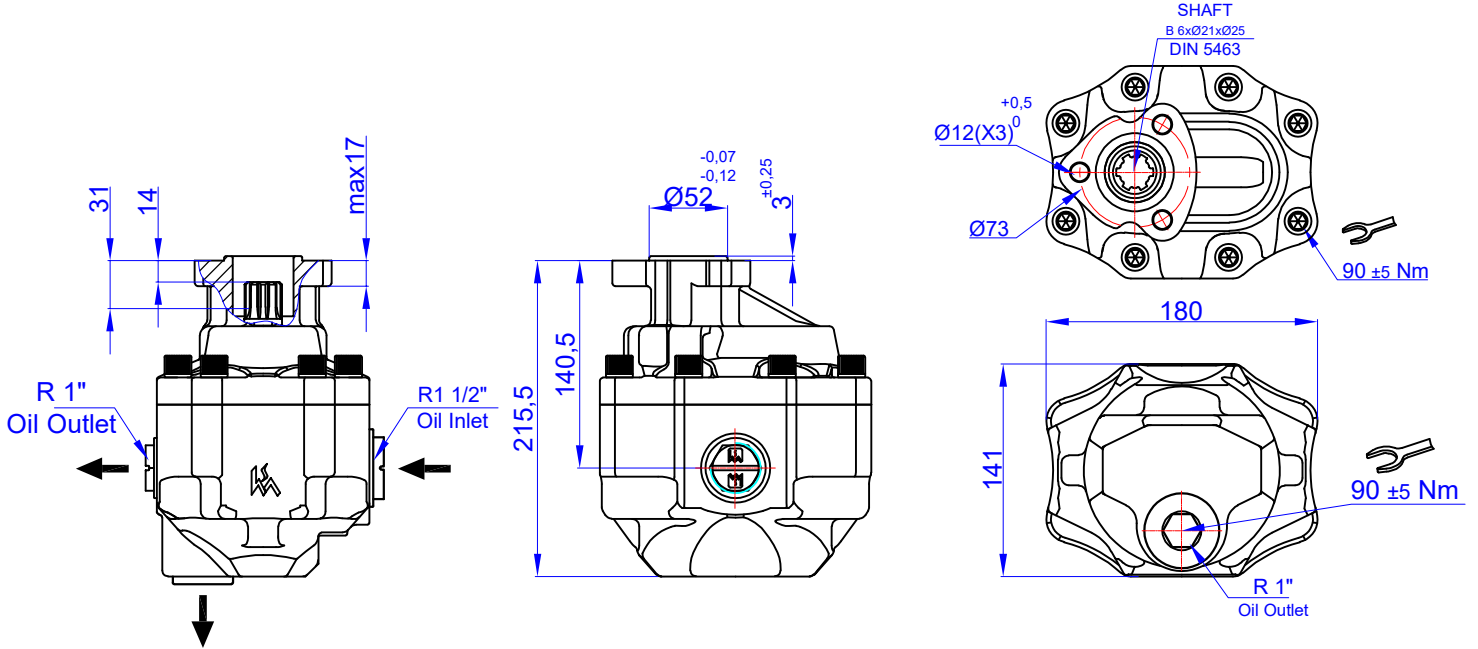

TEKNİK BİLGİLER / TECHNICAL DATA

Specifications		
Displacement	151	cm ³ /rev
Max. Peak Pressure (P3)	210	bar
Max. Intermittent Pressure (P2) (for tipping applications)	195	bar
Max. Continuous Pressure (P1)	170	bar
Max. Speed at Intermittent Press.	1900	min ⁻¹
Min. Speed at Intermittent Press.	300	min ⁻¹
Max. Speed at Continuous Press.	1600	min ⁻¹
Oil Temperature Range	-40 ~ 80	°C
Inlet Pressure Range (suction side)	0,7 ~ 3	bar
Recommended Oil Viscosity Range	12 ~ 100	mm ² /s (cSt)
Max. Starting Viscosity	750	mm ² /s (cSt)
Filtration :		
-Working Pressure < 200 bar	25	µm
-Working Pressure > 200 bar	10	µm
Connection :		
Min. Suction Hose Bore Diameter	--	inch
Weight	21,5	kg
Rust prevent oil applied shaft area	protect 12 moths	

Power and Torque					
Pressure (Bar)	50	100	150	200	210
Torque (Nm)	134	267	401	534	561

Power (kW)					
rpm / Bar	50	100	150	200	210
500	7	14	21	29	30
1000	14	29	43	57	60
1200	17	34	51	69	72
1600	23	46	69	92	96
1900	27	54	82	109	114

rpm (n/min)	Flow (L/min)
500	74
1000	148
1200	178
1600	237
1900	281

DİYAGRAMLAR / DIAGRAMS

Power-Pressure Graphic

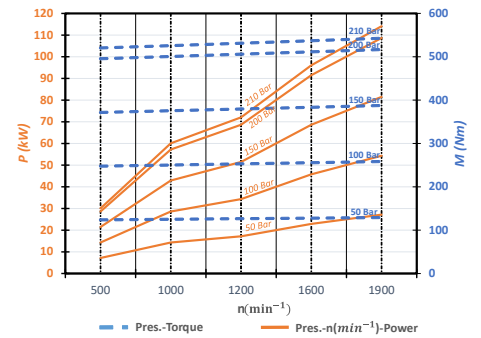

Flow-rpm Graphic

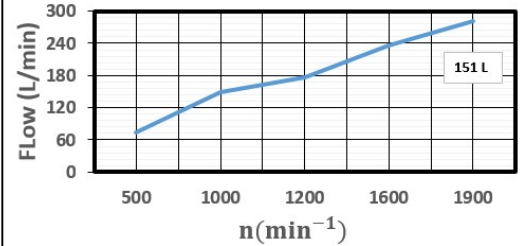

Torque-Pressure Graphic

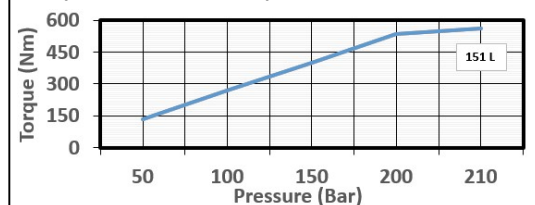

Pressure Definition

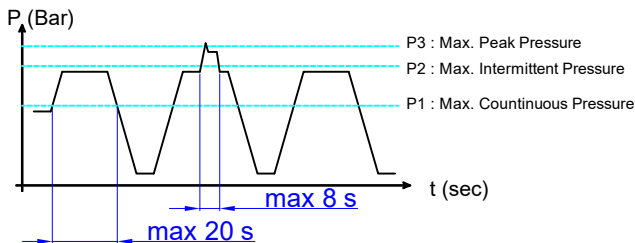

Hydraulic Pump Symbol

