



GALİPOĞLU  
**HIDROMAS**

Phone : +90 332 239 08 52 (pbx)  
 Fax : +90 332 239 08 51  
 Mail : hidromas@hidromas.com  
 Address : Büyükkayacık Mah. Konya O.S.B. 3 Nolu Sk No:1/A 42250  
 SELÇUKLU / KONYA  
 TÜRKİYE

**GHS 116 x 3 x 3075 C**

**Drawing No :43116330753**  
**Reference No :01-001**

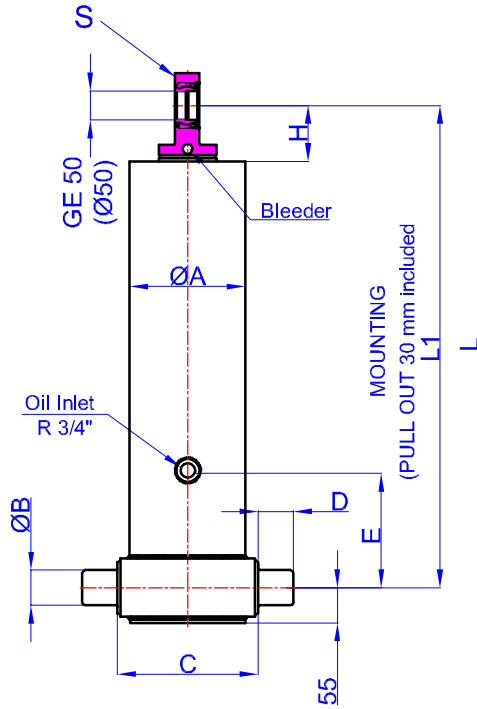

- A : 136 mm
- B : 60 mm
- C : 170 mm
- D : 60 mm
- E : 350 mm
- H : 95 mm
- L : 1312 mm
- \*L1 : 1342 mm
- S : 42 mm

\* Inc 30 mm pull out :  
 tolerance +20 -0  
 Hard Chromed all stages  
 Working Pressure : 170 Bar  
 Max. Working Pressure : 190 Bar  
 All Cylinder Materials are St  
 52 Cold Drawn Tubes

STAGE	1	2	3	4	5	6	7	8	TOTAL
EFFECTIVE DIAMETER (mm)	Ø116	Ø98	Ø80						
STROKE	1025	1025	1025						3075
OIL DISPLACEMENT (L)	11,5	8,5	5,5						29
THRUST AT 170 BAR (TONS)	18	12	8						

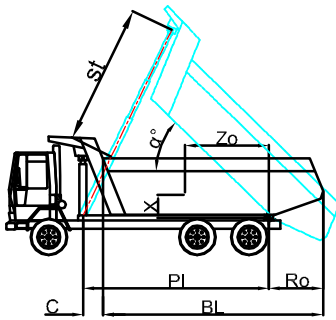

BL (body length)  
 Ro (rear overhang)  
 Ycog (vert. pos. centre of gravity)  
 PI (Pivot length)  
 $\alpha^\circ = \frac{st \times 60}{PI}$

	3800			3700			3600		
BL	200	400	600	200	400	600	200	400	600
Ro	46	49	52	47	50	54	49	52	56
α°									
Ycog	20	24	28	22	25	29	22	26	31
400	25	29	36	26	30	39	26	33	41
700	28	36	43	30	38	45	32	39	46
1000	2913	2940	2946	2898	2916	2970	2940	2946	2986
st									

Weight : 104 Kg

Drawing No :43116330753-02-001