



GALİPOĞLU
HIDROMAS

Phone : +90 332 239 08 52 (pbx)
 Fax : +90 332 239 08 51
 Mail : hidromas@hidromas.com
 Address : Büyükkayacık Mah. Konya O.S.B. 3 Nolu Sk No:1/A 42250
 SELÇUKLU / KONYA
 TÜRKİYE

GHS 116 x 3 x 3195 C

Drawing No :43116331953

Reference No :01-001

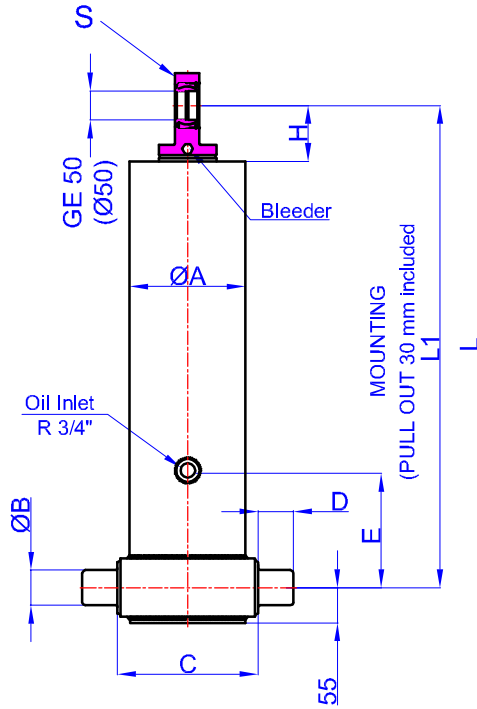

A	:	136	mm
B	:	60	mm
C	:	170	mm
D	:	60	mm
E	:	350	mm
H	:	95	mm
L	:	1352	mm
*L1	:	1382	mm
S	:	42	mm

* Inc 30 mm pull out :
 tolerance +20 -0
 Hard Chromed all stages
 Working Pressure : 170 Bar
 Max. Working Pressure : 190 Bar
 All Cylinder Materials are St
 52 Cold Drawn Tubes

STAGE	1	2	3	4	5	6	7	8	TOTAL
EFFECTIVE DIAMETER (mm)	Ø116	Ø98	Ø80						
STROKE	1065	1065	1065						3195
OIL DISPLACEMENT (L)	13,5	9,5	7						30
THRUST AT 170 BAR (TONS)	18	12	8						

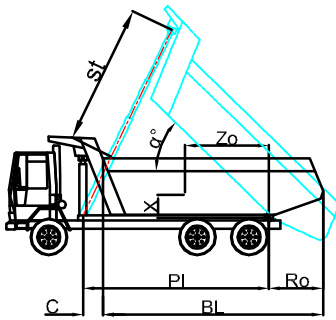

BL (body length)
 Ro (rear overhang)
 Ycog (vert. pos. centre of gravity)
 PI (Pivot length)
 $\alpha^\circ = \frac{st \times 60}{PI}$

BL	200	400	600	200	3900	600	200	3800	600
Ro	45	48	51	47	400	53	48	400	54
Ycog	400	21	24	27	21	24	28	22	25
	700	24	28	33	25	29	36	25	30
	1000	28	33	42	29	35	42	30	38
st	3000	3040	3060	3055	3021	3091	3040	3060	3060

Weight : 107 Kg

Drawing No :43116331953-02-001