



GALİPOĞLU
HIDROMAS

Phone : +90 332 239 08 52 (pbx)
 Fax : +90 332 239 08 51
 Mail : hidromas@hidromas.com
 Address : Büyükkayacık Mah. Konya O.S.B. 3 Nolu Sk No:1/A 42250
 SELÇUKLU / KONYA
 TÜRKİYE

GHS 155 x 3 x 3855 C

Stock Code : 43155338553

Reference No : 01-001

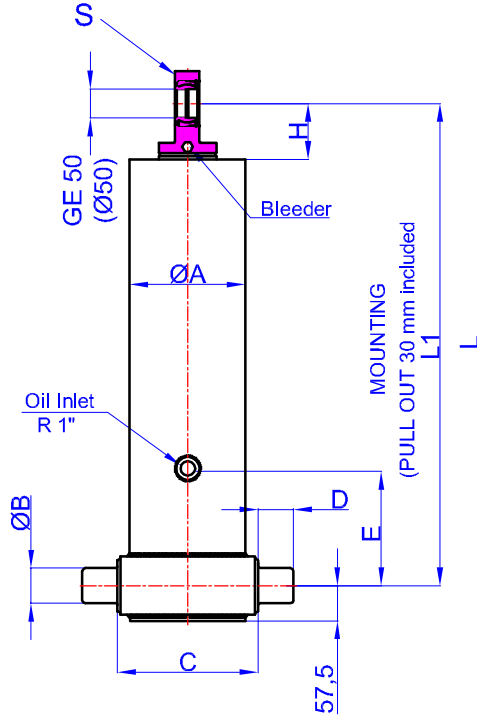

- A : 175 mm
- B : 60 mm
- C : 215 mm
- D : 60 mm
- E : 350 mm
- H : 95 mm
- L : 1600 mm
- *L1 : 1630 mm
- S : 42 mm

* Inc 30 mm pull out :
 tolerance +20 -0
 Hard Chromed all stages
 Working Pressure : 170 Bar
 Max. Working Pressure : 190 Bar
 All Cylinder Materials are St
 52 Cold Drawn Tubes

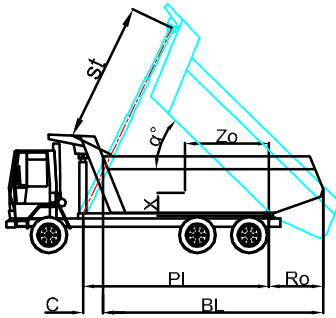

STAGE	1	2	3	4	5	6	7	8	TOTAL
EFFECTIVE DIAMETER (mm)	Ø154,5	Ø135	Ø116						
STROKE	1285	1285	1285						3855
OIL DISPLACEMENT (L)	26	19,5	14,5						71
THRUST AT 170 BAR (TONS)	31	24	18						

BL (body length)
 Ro (rear overhang)
 Ycog (vert. pos. centre of gravity)
 PI (Pivot length)
 $\alpha^\circ = \frac{st \times 60}{PI}$

	4900			4700			4500		
BL	200	500	800	200	500	800	200	500	800
Ro	45	48	52	46	51	55	49	53	58
Ycog	600	50	58	71	52	61	76	54	65
	900	56	66	79	58	70	83	61	72
	1200	62	72	85	65	75	86	67	78
st	3675	3680	3726	3603	3740	3758	3675	3710	3770

Weight : 181 Kg

Drawing No : 43155338553-02-001