



GALİPOĞLU  
**HIDROMAS**

Phone : +90 332 239 08 52 (pbx)  
 Fax : +90 332 239 08 51  
 Mail : hidromas@hidromas.com  
 Address : Büyükkayacık Mah. Konya O.S.B. 3 Nolu Sk No:1/A 42250  
 SELÇUKLU / KONYA  
 TÜRKİYE

**GHS 155 x 5 x 5125 C**

Stock Code : 43155551253

Reference No : 01-001

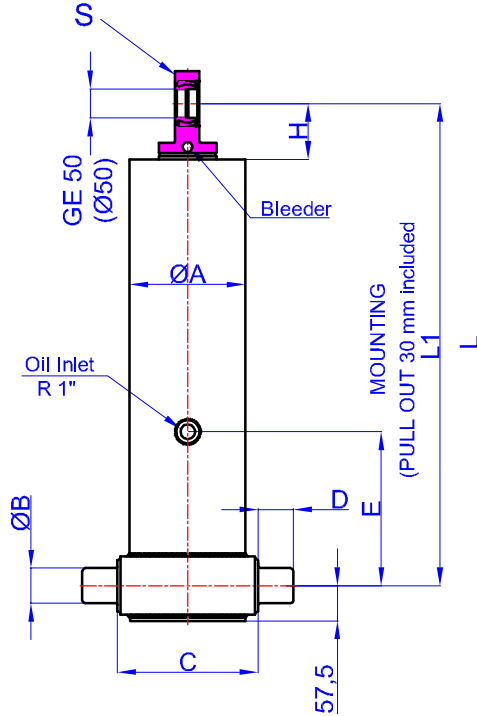

- A : 175 mm
- B : 60 mm
- C : 215 mm
- D : 60 mm
- E : 350 mm
- H : 95 mm
- L : 1310 mm
- \*L1 : 1340 mm
- S : 42 mm

\* Inc 30 mm pull out :  
 tolerance +20 -0  
 Hard Chromed all stages  
 Working Pressure : 170 Bar  
 Max. Working Pressure : 190 Bar  
 All Cylinder Materials are St  
 52 Cold Drawn Tubes

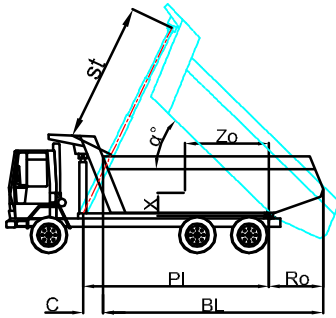

STAGE	1	2	3	4	5	6	7	8	TOTAL
EFFECTIVE DIAMETER (mm)	Ø154,5	Ø135	Ø116	Ø98	Ø80				
STROKE	1025	1025	1025	1025	1025				5125
OIL DISPLACEMENT (L)	20,5	15,5	11,5	8,5	6				67,4
THRUST AT 170 BAR (TONS)	31	24	18	12	8				

BL (body length)  
 Ro (rear overhang)  
 Ycog (vert. pos. centre of gravity)  
 PI (Pivot length)  
 $\alpha^\circ = \text{st} \times 60 / \text{PI}$

	6600			6400			6200		
BL	200	500	800	200	500	800	200	500	800
Ro	45	47	49	46	49	51	48	50	53
Ycog	600	21	24	27	22	25	28	23	26
	900	24	27	31	24	28	33	25	29
	1200	26	30	37	27	32	40	28	35
st	4950	4935	4900	4906	4981	4930	4960	4916	4946

Weight : 171,5 Kg

Drawing No : 43155551253-02-001