



GALİPOĞLU®
HIDROMAS

Phone : 90.332 239 08 52 (pbx)

Fax : 90.332 239 08 51

Mail : hidromas@hidromas.com

Address : Büyükkayacık Mah. Konya O.S.B. 3 Nolu Sk No:1/A 42250

SELÇUKLU / KONYA

TÜRKİYE

GHS 175-4-4100 C TEL.SİL.

Product Code :

43175441003

Reference No :

01-001

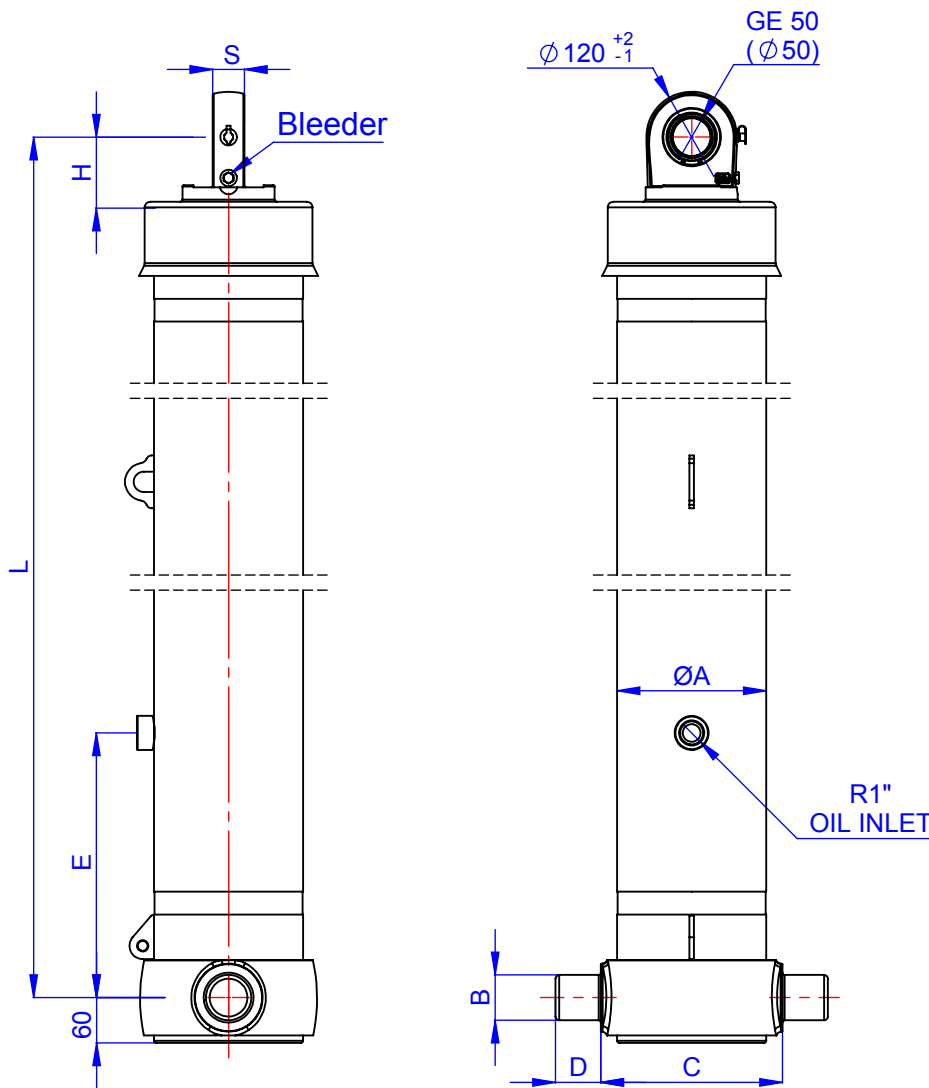

A	: 197
B	: 60
C	: 240
D	: 60
E	: 350
F	:
G	:
H	: 94
I	:
J	:
K	:
L	: 1307
*L	: +30
M	:
N	:
O	:
P	:
R	:
S	: 42
S1	:
T	:
U	:
V	:
W	:
Y	:
Z	:

EFFECTIVE DIAMETER (mm)				175	155	135	116				
STROKE (mm)				1025	1025	1025	1025				
THRUST AT 170 BAR (TONS)				40.5	31.7	24.1	17.8				

All sizes were given as mm

SPECIFICATIONS

- Stroke : 4100
- *Inc 30 mm pull out : Tolerance +20 ; 0
- Working pressure : 170 Bar
- Max. working pressure : 190 Bar
- Working Temperature : -23 °C / +80 °C
- Total Volume : 84.3 L
- Weight Cylinder : 196,3 kg
- Hard cromed all stages
- All cylinder materials are st 52 cold down tubes
- Standard cylinder is painted with RAL 1036

FORMULATION

- St : (Stroke)
- BL : (Body Length)
- Ro : (Rear Overhang)
- PI : (Pivot Length)
- C : (Bracket Length)

$$\alpha^\circ = \frac{St \times 60}{PI}$$

