



GALİPOĞLU
HIDROMAS

Phone : +90 332 239 08 52 (pbx)
 Fax : +90 332 239 08 51
 Mail : hidromas@hidromas.com
 Address : Büyükkayacık Mah. Konya O.S.B. 3 Nolu Sk No:1/A 42250
 SELÇUKLU / KONYA
 TÜRKİYE

GHS 175 x 4 x 4440 C

Stock Code : 43175444403

Reference No : 01-001

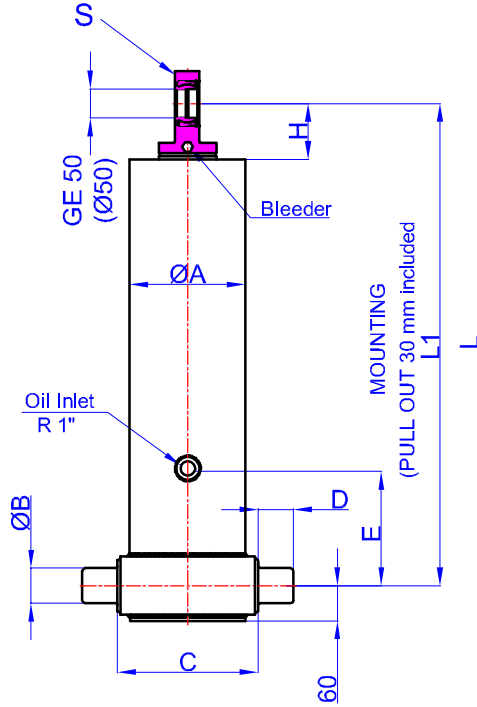

- A : 197 mm
- B : 60 mm
- C : 240 mm
- D : 60 mm
- E : 350 mm
- H : 95 mm
- L : 1397 mm
- *L1 : 1427 mm
- S : 42 mm

* Inc 30 mm pull out :
 tolerance +20 -0
 Hard Chromed all stages
 Working Pressure : 170 Bar
 Max. Working Pressure : 190 Bar
 All Cylinder Materials are St
 52 Cold Drawn Tubes

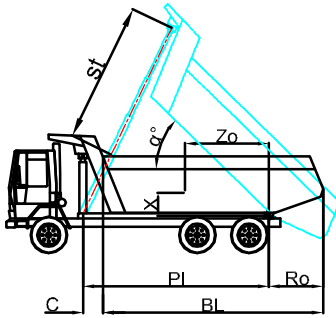

STAGE	1	2	3	4	5	6	7	8	TOTAL
EFFECTIVE DIAMETER (mm)	Ø175	Ø154,5	Ø135	Ø116					
STROKE	1110	1110	1110	1110					4440
OIL DISPLACEMENT (L)	28	22	17	12,5					86
THRUST AT 170 BAR (TONS)	40	31	24	18					

BL (body length)
 Ro (rear overhang)
 Ycog (vert. pos.
 centre of gravity)
 PI (Pivot lengt)
 $\alpha^\circ = st \times 60$
 PI

BL	5600			5400			5200			
Ro	200	500	800	200	500	800	200	500	800	
α°	45	48	51	46	50	54	49	52	56	
Ycog	600	52	59	70	53	62	61	56	65	81
	900	58	67	83	60	72	88	63	78	93
	1200	64	78	92	69	82	98	73	86	102
st	4200	4240	4250	4140	3995	4000	4246	4246	4293	

Weight : 219 Kg

Drawing No :43175444403-02-001