



GALİPOĞLU
HIDROMAS

Phone : +90 332 239 08 52 (pbx)
 Fax : +90 332 239 08 51
 Mail : hidromas@hidromas.com
 Address : Büyükkayacık Mah. Konya O.S.B. 3 Nolu Sk No:1/A 42250
 SELÇUKLU / KONYA
 TÜRKİYE

GHS 197 x 5 x 7100 C

Stock Code : 43197571003

Reference No : 03-001

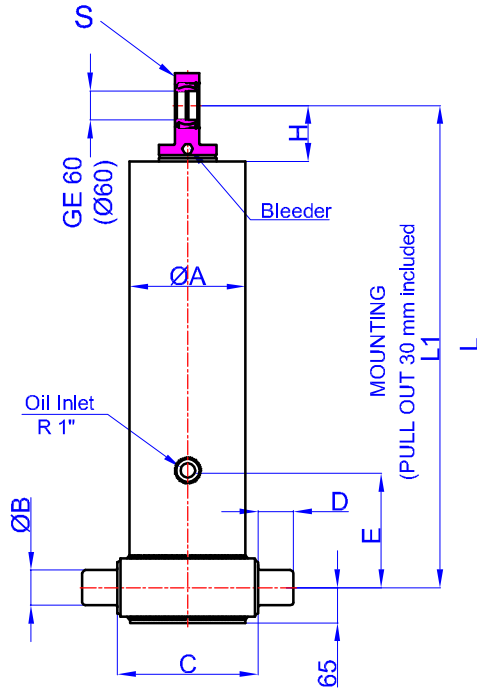

A	:	220	mm
B	:	65	mm
C	:	265	mm
D	:	60	mm
E	:	400	mm
H	:	95	mm
L	:	1745	mm
*L1	:	1775	mm
S	:	52	mm

* Inc 30 mm pull out :
 tolerance +20 -0
 Hard Chromed all stages
 Working Pressure : 150 Bar
 Max. Working Pressure : 180 Bar
 All Cylinder Materials are St
 52 Cold Drawn Tubes

STAGE	1	2	3	4	5	6	7	8	TOTAL
EFFECTIVE DIAMETER (mm)	Ø197	Ø175	Ø154,5	Ø135	Ø116				
STROKE	1420	1420	1420	1420	1420				7100
OIL DISPLACEMENT (L)	45,5	36	28,5	21,5	16,5				160
THRUST AT 150 BAR (TONS)	51	40	31	24	18				

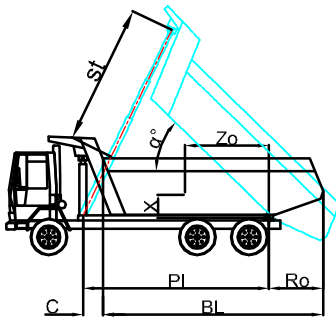

BL (body length)
 Ro (rear overhang)
 Ycog (vert. pos. centre of gravity)
 PI (Pivot length)
 $\alpha^\circ = \text{st} \times 60$
 PI

BL	200	9100							
Ro	500	800							
α°	45	46	48						
Ycog	600	49	52	56					
	900	51	56	61					
	1200	55	60	66					
st	6825	6746	6800	6823	6880	6778	6815	6860	7055

Weight : 350 Kg

Drawing No :43197571003-16-001